



2x09, 2x12, 2x18, 2x24, 2x30 BTU/H



**13 SEER R410A System**

# Wall Mount Mini Split System-Dual Zone

- \* World-class Compressors (TOSHIBA, HITACHI, PANASONIC, SANYO)
- \* Flexible/Easy/Quick Set-up, User Friendly and Stylish Looking
- \* Quiet Operation, Zone-Controlled, Energy and Cost Saving
- \* Each Indoor Unit Can Run Either Cooling or Heating (For Example, Cooling in Computer Rooms, and Heating in Offices)
- \* Work Better in Hot or Cold Weather than Most of Others

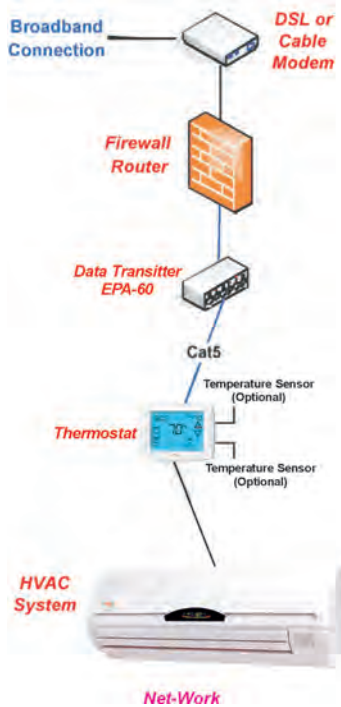

**Cooling Only & Heat Pump (W or W/O Supplemental Ele. Heater)**



**YMG, A Comfort Maker, A Joy Companion, A Satisfaction Guarantor...**

### APPLICATIONS:

- \* HIGH-RISE BUILDING
- \* HOTELS
- \* HOMES
- \* SUNROOMS
- \* CONDOS
- \* RESORTS
- \* FACTORIES
- \* NURSING ROOMS
- \* APARTMENTS
- \* OFFICES
- \* RESTARAUNTS
- \* MOBILE HOMES

### FEATURES:

- \* OPTIMIZED SYSTEM DESIGN
- \* QUICK COOLING AND HEATING
- \* INDEPENDENT DEHUMIDIFICATION
- \* INTELLIGENT/MECHANICAL DEFROSTING
- \* QUIET OPERATION
- \* MULTI-FOLD EVAPORATOR
- \* RANDOM PITCH CROSS FLOW FAN WHEEL
- \* WIDE ANGLE AIR SPREAD
- \* BIOLOGICALLY ACTIVATED ENZYME
- \* WASHABLE FILTER
- \* REMOTE/LINE CONTROLLER
- \* 24-HOUR TIMER
- \* MEMORIES
- \* SUPPLEMENTAL ELECTRIC HEATER IN COLD WEATHER
- \* ANTI-COLD BLOWING DURING HEATING SEASON
- \* OVERCURRENT & THERMAL PROTECTION
- \* SLEEP MODE
- \* ENHANCED COPPER/COIL
- \* PRE-CHARGED
- \* DIGITAL DISPLAY
- \* STYLISH LOOKING
- \* EASY INSTALLATION
- \* EASY OPERATION
- \* THOROUGHLY TESTED
- \* RELIABLE QUALITY

### ADD-ON ACCESSORIES AND PARTS:

- \* WALL MOUNT THERMOSTAT CAPABLE CONTROL BOARD
- \* WIRELESS PHONE CONTROLLER
- \* LOW AMBIENT CONTROL
- \* REMOTE CONTROLLER LOCK
- \* BRACKETS (FOR OUTDOOR UNIT)
- \* FOOT RISERS (FOR OUTDOOR UNIT)
- \* COPPER/WIRE/ACC.SET (ACC. KIT)
- \* LINESSET COVERS
- \* WINTER WIND BAFFLE

YMG Group is the Sole Owner & User of YMG Brand. Any Infringement Is to Be Prohibited and Prosecuted. Reporting or Assisting to Stop Any Infringement is to Be Rewarded.

YMG is the Trademark and Property of YMG Group. Copyright of YMG Group.

Proudly Designed and Manufactured and Distributed and Marketed by YMG Group LLC. No Other Persons or Companies in the World, Including China, USA and Canada, Are Authorized to Use YMG Brand. Reporting or Assisting to Stop Any Infringement is to Be Rewarded.



**OPTIONS AT MANUFACTURE:**

- \* Rust-free Cabinet
- \* Treated Coil
- \* Plug & Connect Valves
- \* Low Ambient Control
- \* Wall Mount Line Control
- \* Wall Mount Thermostat Control
- \* Cabled Defrost Control
- \* Advanced Filter Kit
- \* Plug & Connect Copper Line Set



2x9,000, 2x12,000, 2x18,000, 2x24,000, 2x30,000 Btu/h  
Cooling Only, Heat Pump, Heat Pump+Heater

COOLING ONLY	MODELS	SYSTEM MODEL	WMMS-2x09K-31B	WMMS-2x12K-31B	WMMS-2x18K-31B	WMMS-2x24K-31B	WMMS-2x30K-31B	WMMS-0912K-31B
		INDOOR UNIT	WMMS-09F(E)-31B	WMMS-12F(E)-31B	WMMS-18F(E)-31B	WMMS-24F(E)-31B	WMMS-30F(E)-31B	WMMS-09/12F(E)-31B
		OUTDOOR UNIT	WMMS-2x09C-31B	WMMS-2x12C-31B	WMMS-2x18C-31B	WMMS-2x24C-31B	WMMS-2x30C-31B	WMMS-0912C-31B
HEAT PUMP	MODELS	SYSTEM MODEL	WMMS-2x09K-32B	WMMS-2x12K-32B	WMMS-2x18K-32B	WMMS-2x24K-32B	WMMS-2x30K-32B	WMMS-0912K-32B
		INDOOR UNIT	WMMS-09F(E)-32B	WMMS-12F(E)-32B	WMMS-18F(E)-32B	WMMS-24F(E)-32B	WMMS-09F(E)-32B	WMMS-09/12F(E)-32B
		OUTDOOR UNIT	WMMS-2x09C-32B	WMMS-2x12C-32B	WMMS-2x18C-32B	WMMS-2x24C-32B	WMMS-2x30C-32B	WMMS-0912C-32B
HEAT PUMP+ELE. HEATER	MODELS	SYSTEM MODEL	WMMS-2x09K-34B	WMMS-2x12K-34B	WMMS-2x18K-34B	WMMS-2x24K-34B	WMMS-2x30K-34B	WMMS-0912K-34B
		INDOOR UNIT	WMMS-09F(E)-34B	WMMS-12F(E)-34B	WMMS-18F(E)-34B	WMMS-24F(E)-34B	WMMS-30F(E)-34B	WMMS-09/12F(E)-34B
		OUTDOOR UNIT	WMMS-2x09C-32B	WMMS-2x12C-32B	WMMS-2x18C-32B	WMMS-2x24C-32B	WMMS-2x30C-32B	WMMS-0912C-32B
REF. TUBE/WIRE INS. KIT	Copper Sets, Wiring, Putty, Wall Sleeve, Wrap, Drain Hose	INST-1438-xx	INST-1412-xx	INST-3858-xx	INST-3858-xx	INST-3834-xx	INST-1438, 1412-xx	
COOLING CAPACITY	RATED	BTU/H	2x9000	2x12000	2x18000	2x24000	2x30000	9000+12000
HEATING CAPACITY	RATED	BTU/H	2x9500	2x12800	2x19000	2x25000	2x31000	9500+12800
ELECTRIC HEATER (SUP)	HEATING BOOSTER	W	2x800	2x1000	2x1200	2x1200	2x1500	800+1000
DEHUMIDIFICATION	RATED	PTS./H	2x3.4	2x4.6	2x6.9	2x7.6	2x8.4	3.4+4.6
SEER	RATED	BTU/H.W	13					
HSPF	RATED	BTU/H.W	9.2					
SOUND LEVEL (POWER)	INDOOR/OUTDOOR	dB(a)	2x40/(50-52)	2x41/(51-53)	2x45/(51-53)	2x45/(53-55)	2x45/(53-55)	40+41/(50-53)
REFRIGERANT	PRE-CHARGED FOR 25' TUBING	R410A						
POWER	CIRCUIT BRAKER TO OUTDOOR TO INDOOR UNIT	B: 208-230/1/60						
TOTAL CURRENT	W/O HEATER	AMP	$2x(0.1+4.5)+0.6$	$2x(0.2+5.9)+0.9$	$2x[0.3+(0.6+8.7)]$	$2x[0.4+(0.9+12.0)]$	$2x[0.4+(1.3+14.5)]$	$(0.1+4.5)+(0.2+5.9)+0.9$
	WITH HEATER	AMP	$2x[(0.1+3.5)+4.5]+0.6$	$2x[(0.2+4.4)+5.9]+0.9$	$2x[(0.3+5.2)+(0.6+8.7)]$	$2x[(0.4+5.2)+(0.9+12.0)]$	$2x[(0.4+6.5)+(1.3+14.5)]$	$[(0.1+3.5)+4.5]+[(0.2+4.4)+5.9]+0.9$
MCA	W/O HEATER	AMP	12.6=2x6.3	17.0=2x8.5	23.6=2x11.8	32.6=2x16.3	39.6=2x19.8	15.1=6.6+8.5
	WITH HEATER	AMP	21.4=2x10.7	28.0=2x14.0	36.4=2x18.2	45.6=2x22.8	56.0=2x28.0	25.0=11.0+14.0
HVAC CIRCUIT BREAKER SIZE	W/O HEATER	AMP	20.0=2x10.0	20.0=2x10.0	40.0=2x20.0	50.0=2x25.0	60.0=2x30.0	20.0=10.0+10.0
	WITH HEATER	AMP	30.0=2x15.0	30.0=2x15.0	50.0=2x25.0	60.0=2x30.0	80.0=2x40.0	30.0=15.0+15.0
INDOOR FAN MOTOR	FAN	TYPE	CROSS FLOW					
		CFM	2x295	2x365	2x565	2x765	2x765	295+365
	MOTOR (PSC)	RATED AMP	2x0.10	2x0.20	2x0.30	2x0.40	2x0.40	0.10+0.20
OUTDOOR FAN MOTOR	FAN	TYPE	PROPELLER					
		CFM	1765	2350	3530	4350	5450	2350
	MOTOR (PSC)	RATED AMP	0.60	0.90	2x0.60	2x0.90	2x1.30	0.90
	SPEED	1						
COMPRESSOR	HERMETIC	TYPE	ROTARY					
		RLA (AMP)	2x4.5	2x5.9	2x8.7	2x12.0	2x14.5	4.5+5.9
		LRA (AMP)	2x26	2x29	2x41	2x45	2x70	26+29
CONNECTION TUBE	DRAIN	DRAIN PIPE	1/2"ID 3/4"OD					
	REFRIGERANT	LIQUID	2x1/4"	2x1/4"	2x3/8"	2x3/8"	2x3/8"	2x1/4"
MAXIMUM REF. TUBE	LIFT	FT	25	25	25	25	25	25
		DROP	25	25	25	25	25	25
	TOTAL LENGTH	FT	2x50	2x50	2x65	2x75	2x75	2x50
WEIGHT	INDOOR-NET	LBs	2x17	2x25	2x33	2x42	2x42	17+25
	INDOOR GROSS	LBs	2x23	2x28	2x36	2x48	2x48	23+28
	OUTDOOR-NET	LBs	112	135	200	229	257	128
	OUTDOOR GROSS	LBs	121	145	233	266	295	138
DIMENSION W×H×D	INDOOR-NET	INCH	31x11x7	36x11x8	41x12x8	49x13x9		31x11x7+36x11x8
	INDOOR-BOX	INCH	34x13x11	39x14x11	44x15x11	52x14x13		34x13x11+39x14x11
	OUTDOOR-NET	INCH	33x28x15	35x31x17	33x48x15	37x49x17		33x28x15
	OUTDOOR-BOX	INCH	39x30x17	41x34x19	39x51x17	42x52x19		39x30x17
LOADING CAPACITY	20'/40'/40'HQ	SETS	68/145/162	50/102/115	43/85/96	33/68/76		50/102/115

**YMG Group LLC**

POB 1559, O'Fallon, MO 63366, USA  
Tel: 1-866-833-3138  
Fax: 1-866-377-3355  
Web Sites: www.ymggroup.com  
Email: info@ymggroup.com

**Rep. Or Distributor:**

Proudly Designed and Manufactured and Marketed by YMG Group LLC. No Other Persons or Companies in the World, Including China, USA and Canada, Are Authorized to Use YMG Brand. Reporting or Assisting to Stop Any Infringement is to Be Rewarded.