

# ATUF/ARUF/ARPF/ADPF/AEPF/ASPF AIR HANDLERS

## INSTALLATION & OPERATING INSTRUCTIONS



**NOTE: ATUF models are suitable for Upflow and Horizontal Installations only. Do not use for Downflow Installations**



**RECOGNIZE THIS SYMBOL AS A SAFETY PRECAUTION.**

### **ATTENTION INSTALLING PERSONNEL**

Prior to installation, thoroughly familiarize yourself with this Installation Manual. Observe all safety warnings.  
During installation or repair, caution is to be observed.

It is your responsibility to install the product safely and to educate the customer on its safe use.

Goodman Manufacturing Company, L.P.  
5151 San Felipe, Suite 500, Houston, TX 77056  
[www.goodmanmfg.com](http://www.goodmanmfg.com)

© 2004-2008 Goodman Manufacturing Company, L.P.



# Contents

Important Safety Instructions .....	3
Shipping Inspection .....	3
Codes & Regulations .....	3
Replacement Parts .....	4
Pre-Installation Instructions .....	4
Location .....	4
Ductwork .....	4
<i>Return Ductwork</i> .....	4
<i>Return Air Filters</i> .....	4
Electric Heat .....	4
HKR Installation .....	5
Electrical Supply Wire and MOP .....	5
<i>Building Electrical Service Inspection</i> .....	5
<i>Wire Sizing</i> .....	5
<i>Maximum Overcurrent Protection (MOP)</i> .....	6
<i>Electrical Connections – Supply Voltage</i> .....	6
<i>Air Handler Only (Non-Heat Kit Models)</i> .....	6
<i>Air Handler With Non-Circuit Breaker Heat Kits</i> .....	6
<i>Air Handler With Heat Kits Containing a Circuit Breaker</i> .....	6
<i>Low Voltage Connections</i> .....	6
Refrigerant Lines .....	6
<i>Tubing Preparation</i> .....	6
<i>Post Brazing</i> .....	6
<i>Piping Size</i> .....	6
<i>Special Instructions</i> .....	6
Downflow Conversion .....	7
Horizontal Conversion .....	8
AEPF MOTOR ORIENTATION .....	9
Condensate Removal .....	9
ACHIEVING 2% LOW LEAKAGE RATE .....	9
ATUF/ARUF/ARPF/ADPF MOTOR .....	9
AEPF Motor .....	9
<i>Motor Speed Adjustment</i> .....	9
<i>Dipswitch Functions</i> .....	9
<i>CFM Delivery</i> .....	10
<i>Thermostat “Fan Only Mode”</i> .....	10
<i>CFM Trim Adjust</i> .....	10
<i>Humidity Control</i> .....	10
<i>Two Stage Heating</i> .....	10
ASPF Motor .....	10
<i>CFM Delivery</i> .....	10
Thermostats .....	10
Start-Up Procedure .....	11
Regular Maintenance .....	11
THERMOSTAT WIRING .....	13
ASPF THERMOSTAT CONNECTIONS .....	16
COOLING UNIT WITH OPTIONAL HEAT KITS OF 10kW AND BELOW .....	16
COOLING UNIT WITH OPTIONAL HEAT KITS OF 15 kW AND ABOVE AND ROOM THERMOSTAT WITH TWO STAGES OF HEAT .....	17
HEAT PUMP UNIT WITH OPTIONAL HEAT KITS OF 10kW AND BELOW .....	17
HEAT PUMP UNIT WITH OPTIONAL HEAT KITS OF 15 kW AND ABOVE .....	18
ELECTRONIC BLOWER TIME DELAY RELAY .....	19

## Important Safety Instructions

The following symbols and labels are used throughout this manual to indicate immediate or potential safety hazards. It is the owner's and installer's responsibility to read and comply with all safety information and instructions accompanying these symbols. Failure to heed safety information increases the risk of personal injury, property damage, and/or product damage.

### WARNING

#### HIGH VOLTAGE!

Disconnect ALL power before servicing. Multiple power sources may be present. Failure to do so may cause property damage, personal injury or death.



### WARNING

Installation and repair of this unit should be performed **ONLY** by individuals meeting the requirements of an "entry level technician" as specified by the Air Conditioning and Refrigeration Institute (ARI). Attempting to install or repair this unit without such background may result in product damage, personal injury or death.

### WARNING

To avoid property damage, personal injury or death due to electrical shock, this unit **MUST** have an uninterrupted, unbroken electrical ground. The electrical ground circuit may consist of an appropriately sized electrical wire connecting the ground lug in the unit control box to the building electrical service panel.

Other methods of grounding are permitted if performed in accordance with the National Electric Code (NEC)/American National Standards Institute (ANSI)/National Fire Protection Association (NFPA) 70 and local/state codes. In Canada, electrical grounding is to be in accordance with the Canadian Electric Code (CSA) C22.1.

### WARNING

This product is factory-shipped for use with 208/240/1/60 electrical power supply. **DO NOT** reconfigure this air handler to operate with any other power supply.

### CAUTION

When installing or servicing this equipment, safety clothing, including hand and eye protection, is strongly recommended. If installing in an area that has special safety requirements (hard hats, etc.), Observe these requirements.

### WARNING

Do not connect to or use any device that is not design-certified by Goodman for use with this unit. Serious property damage, personal injury, reduced unit performance and/or hazardous conditions may result from the use of such non-approved devices.

### WARNING

To prevent the risk of property damage, personal injury, or death, do not store combustible materials or use gasoline or other flammable liquids or vapors in the vicinity of this unit.

**DANGER**  
**PELIGRO**

  
**CARBON MONOXIDE POISONING HAZARD**

**Special Warning for Installation of Furnace or Air Handling Units in Enclosed Areas such as Garages, Utility Rooms or Parking Areas**

Carbon monoxide producing devices (such as an automobile, space heater, gas water heater, etc.) should not be operated in enclosed areas such as unventilated garages, utility rooms or parking areas because of the danger of carbon monoxide (CO) poisoning resulting from the exhaust emissions. If a furnace or air handler is installed in an enclosed area such as a garage, utility room or parking area and a carbon monoxide producing device is operated therein, there must be adequate, direct outside ventilation.

This ventilation is necessary to avoid the danger of CO poisoning which can occur if a carbon monoxide producing device continues to operate in the enclosed area. Carbon monoxide emissions can be (re)circulated throughout the structure if the furnace or air handler is operating in any mode.

CO can cause serious illness including permanent brain damage or death.

B10259-216

## Shipping Inspection

Always keep the unit upright; laying the unit on its side or top may cause equipment damage. Shipping damage, and subsequent investigation is the responsibility of the carrier. Verify the model number, specifications, electrical characteristics, and accessories are correct prior to installation. The distributor or manufacturer will not accept claims from dealers for transportation damage or installation of incorrectly shipped units.

## Codes & Regulations

This product is designed and manufactured to comply with national codes. Installation in accordance with such codes and/or prevailing local codes/regulations is the responsibility of the installer. The manufacturer assumes no responsibility for equipment installed in violation of any codes or regulations.

The United States Environmental Protection Agency (EPA) has issued various regulations regarding the in-

**roduction and disposal of refrigerants. Failure to follow these regulations may harm the environment and can lead to the imposition of substantial fines.** Should you have any questions please contact the local office of the EPA.

### Replacement Parts

When reporting shortages or damages, or ordering repair parts, give the complete product model and serial numbers as stamped on the product. Replacement parts for this product are available through your contractor or local distributor. For the location of your nearest distributor consult the white business pages, the yellow page section of the local telephone book or contact:

SERVICE PARTS DEPARTMENT  
 GOODMAN MANUFACTURING COMPANY, L.P.  
 5151 SAN FELIPE, SUITE 500  
 HOUSTON, TEXAS 77056  
 (713) 861 – 2500

If replacing an air handler, the system must be manufacturer approved and Air Conditioning and Refrigeration Institute (ARI) matched. **NOTE:** Installation of unmatched systems is strongly discouraged.

### Pre-Installation Instructions

Carefully read all instructions for the installation prior to installing product. Make sure each step or procedure is understood and any special considerations are taken into account before starting installation. Assemble all tools, hardware and supplies needed to complete the installation. Some items may need to be purchased locally. Make sure everything needed to install the product is on hand before starting.

### Location

**NOTE:** Air handlers are designed for *indoor installation only*.

Give special consideration to minimizing the length of refrigerant tubing when installing air handlers. Refer to Remote Cooling/Heat Pump Service Manual, TP-106 Long Line Set Application R-22 or TP-107 Long Line Set Application R-410A for guidelines. The unit clearance from a combustible surface may be 0". However, service clearance is to take precedence. In addition allow a minimum of 24" in front of the unit for service clearance.

Do not install the air handler in a location that violates the instructions provided with the condenser.

Consult all appropriate regulatory codes prior to determining final clearances. When installing this unit in an area that may become wet, elevate the unit with a sturdy, non-porous material. In installations that may lead to physical damage (i.e. a garage) it is advised to install a protective barrier to prevent such damage.

### Ductwork

This air handler is designed for a complete supply and return ductwork system.



**CAUTION**

**Do not operate this product without all the ductwork attached.**

To ensure correct system performance, the ductwork is to be sized to accommodate 375-425 CFM per ton of cooling with the static pressure not to exceed .5" WC. Inadequate ductwork that restricts airflow can result in improper performance and compressor or heater failure. Ductwork is to be constructed in a manner that limits restrictions and maintains suitable air velocity. Ductwork is to be sealed to the unit in a manner that will prevent leakage.

### Return Ductwork

DO NOT TERMINATE THE RETURN DUCTWORK IN AN AREA THAT CAN INTRODUCE TOXIC, OR OBJECTIONABLE FUMES/ODORS INTO THE DUCTWORK. The return ductwork is to be introduced into the air handler bottom (upflow configuration).

### Return Air Filters

Each installation must include a return air filter. This filtering may be performed at the air handler or externally such as a return air filter grille. Air handlers mounted in the downflow orientation, including "B" series, require external filtering. A washable filter is available as an accessory. To ensure optimum performance frequent filter cleaning is advised. Refer to **Table 1** for the appropriate filter.

ATUF	ARUF ARPF	ADPF	AEPF ASPF	Filter Number	Qty Required
1824	1729 1824	1824	N/A	FIL 18-32	1
3030 1931 3636	3030 1931 3636	3030	1830	FIL 36-42	1
3642 3743 4860	3642 3743 4860	3042 4860	3036 4260	FIL 48-61	1

Table 1

### Electric Heat

Refer to this manual in combination with the instructions provided with the heat kit for the correct installation procedure.

The air handlers listed in this manual do not have factory installed electric heat. Electric heat is available as an accessory. If installing this option, the **ONLY** heat kits that can be used are the HKR series.

**NOTE:** The Amana® brand EHK, ECB, EDB, and EDK kits are **NOT** approved for use with these air handlers.

The heating mode temperature rise is dependent upon the system airflow, the supply voltage, and the heat kit size (kW) selected. Use **Tables 2, 3, and 4** to determine the temperature rise (°F).

CFM	HEAT KIT NOMINAL kW							
	3	5	6	8	10	15	20	21
600	18	28	35	41				
800	13	21	26	31	42			
1000	11	17	21	25	34	50		
1200	9	14	18	21	28	42	56	62
1400	8	12	15	18	24	36	48	53
1600	7	10	13	15	21	31	42	46
1800	6	9	12	14	19	28	37	41
2000	5	8	11	12	17	25	34	37

Table 2

230/1/60 Supply Voltage - Temperature Rise Table °F

CFM	HEAT KIT NOMINAL kW							
	3	5	6	8	10	15	20	21
600	17	27	34	39				
800	13	20	25	30	40			
1000	10	16	20	24	32	48		
1200	8	13	17	20	27	40	53	59
1400	7	11	14	17	23	34	46	51
1600	6	10	13	15	20	30	40	44
1800	6	9	11	13	18	27	36	39
2000	5	8	10	12	16	24	32	35

Table 3

220/1/60 Supply Voltage - Temperature Rise Table °F

CFM	HEAT KIT NOMINAL kW							
	3	5	6	8	10	15	20	21
600	16	25	32	37				
800	12	19	24	38	38			
1000	10	15	19	22	30	46		
1200	8	13	16	19	25	38	51	56
1400	7	11	14	16	22	33	43	48
1600	6	9	12	14	19	28	38	42
1800	5	8	11	12	17	25	34	37
2000	5	8	10	11	15	23	30	34

Table 4

208/1/60 Supply Voltage - Temperature Rise Table °F

**NOTE:** For installations not indicated above the following formula is to be used:

$$TR = (kW \times 3412) \times (\text{Voltage Correction}) \times 1.08 / CFM$$

Where: TR = Temperature Rise

kW = Heater Kit Actual kW

3412 = Btu per kW

Voltage Correction = .96 (230 Supply Volts)  
 = .92 (220 Supply Volts)  
 = .87 (208 Supply Volts)

1.08 = Constant

CFM = Measured Airflow

**NOTE:** The Temperature Rise Tables can also be used to determine the air handler airflow delivery. When using these tables for this purpose set the room thermostat to maximum heat and allow the system to reach steady state conditions.

Insert two thermometers, one in the return air and one in the supply air. The temperature rise is the supply air temperature minus the room air temperature.

Use HKR specification sheets to determine the HKR available for a given air handler.

### HKR Installation

Follow instructions listed in Installation and Operating Instructions shipped with the heat kit.

### Electrical Supply Wire and MOP



### CAUTION

#### FIRE HAZARD!

To avoid the risk of property damage, personal injury or fire, use only copper conductors.



### WARNING

#### HIGH VOLTAGE!

Disconnect ALL power before servicing. Multiple power sources may be present. Failure to do so may cause property damage, personal injury or death.



### WARNING

#### HIGH VOLTAGE!

To avoid property damage, personal injury or death due to electrical shock, this unit **MUST** have an uninterrupted, unbroken electrical ground. The electrical ground circuit may consist of an appropriately sized electrical wire connecting the ground lug in the unit control box to the building electrical service panel.

Other methods of grounding are permitted if performed in accordance with the National Electric Code (NEC)/American National Standards Institute (ANSI)/National Fire Protection Association (NFPA) 70 and local/state codes. In Canada, electrical grounding is to be in accordance with the Canadian Electric Code (CSA) C22.1.

### Building Electrical Service Inspection

This unit is designed for single-phase electrical supply. **DO NOT OPERATE ON A THREE-PHASE POWER SUPPLY.** Measure the power supply to the unit. The supply voltage **must** be in agreement with the unit nameplate power requirements and within the range shown in **Table 5**.

Nominal Input	Minimum Voltage	Maximum Voltage
208/240	187	253

Table 5

### Wire Sizing

Wire size is important to the operation of your equipment. Use the following check list when selecting the appropriate wire size for your unit.

- Wire size must carry the Minimum Circuit Ampacity (MCA).

- Refer to the NEC (USA) or CSA (Canada) for wire sizing. The unit MCA for the air handler and the optional electric heat kit can be found on the unit Series and Rating Plate.
- Wire size allows for no more than a 2% voltage drop from the building breaker/fuse panel to the unit.**

Refer to the latest edition of the National Electric Code or in Canada the Canadian Electric Code when determining the correct wire size. The following table shows the current carrying capabilities for copper conductors rated at 75°C with a 2% voltage drop. Use **Table 6** to determine the voltage drop per foot of various conductors.

Maximum Allowable Length in Feet to Limit Voltage Drop to 2%*								
Wire Size (AWG)	Minimum Circuit Ampacity (MCA)							
	10	15	20	25	30	35	40	45
14	75	50	37	NR	NR	NR	NR	NR
12	118	79	59	47	NR	NR	NR	NR
10	188	125	95	75	63	54	NR	NR
8	301	201	150	120	100	86	75	68
6	471	314	235	188	157	134	118	110

\*Based on NEC 1996

Table 6

### Maximum Overcurrent Protection (MOP)

Every installation must include an NEC (USA) or CEC (Canada) approved overcurrent protection device. Also, check with local or state codes for any special regional requirements.

Protection can be in the form of fusing or HACR style circuit breakers. The Series and Rating Plate can be used as a guide for selecting the MAXIMUM overcurrent device.

**NOTE: Fuses or circuit breakers are to be sized larger than the equipment MCA but not to exceed the MOP.**

### Electrical Connections – Supply Voltage

#### USE COPPER CONDUCTORS ONLY.

A knockout is provided on the air handler top panel or side to allow for the entry of the supply voltage conductors. If the knockouts on the cabinet sides are used for electrical conduit, an adapter ring must be used in order to meet UL1995 safety requirements. An NEC or CEC approved strain relief is to be used at this entry point. The wire is to be sized in accordance with the “Electrical Wire and MOP” section of this manual. Some areas require the supply wire to be enclosed in conduit. Consult your local codes.

### Air Handler Only (Non-Heat Kit Models)

The building supply connects to the stripped black and red wires contained in the air handler electrical compartment cavity. A ground screw is also contained in this area. Attach the supply wires to the air handler conductors as shown in the unit wiring diagram using appropriately sized solderless connectors or other NEC or CEC approved means.

### Air Handler With Non-Circuit Breaker Heat Kits

A terminal block is provided with the HKR kit to attach the power supply and air handler connections. Follow the HKR Installation Manual and wiring diagram for complete wiring details.

### Air Handler With Heat Kits Containing a Circuit Breaker

HKR models with a “C” suffix contain a circuit breaker(s). The air handler has a plastic cover on the access panel that will require either one or both sections to be removed to allow the heat kit circuit breaker(s) to be installed. See the HKR Installation Instructions for further details. The air handler wires and supply wires are installed directly onto the HKR circuit breaker(s) as shown in the HKR Installation Manual and wiring diagram.

### Low Voltage Connections

Several combinations of low voltage schemes are available, depending on the presence of a heat kit and whether the heat kit is single-stage or multi-staging. The low voltage connections are determined by whether the outdoor unit is a condenser or heat pump. The 24V-control voltage connects the air handler to the room thermostat and condenser. Low voltage wiring is to be copper conductors. A minimum of 18AWG must be used for installations up to 50’ and 16AWG for installations over 50’. Low voltage wiring can be connected through the top of the cabinet or either side. See the “Thermostat Wiring” section of this manual for typical low voltage wiring connections.

### Refrigerant Lines



#### WARNING

This product is factory-shipped under pressure. Follow these instructions to prevent injury.



#### WARNING

A quenching cloth is strongly recommended to prevent scorching or marring of the equipment finish when welding close to the painted surfaces. Use brazing alloy of 5% minimum silver content.

### Tubing Preparation

All cut ends are to be round, burr free, and clean. Failure to follow this practice increases the chances for refrigerant leaks. The suction line is spun closed and requires pipe cutters to remove the closed end.

### Post Brazing

Quench all welded joints with water or a wet rag.

### Piping Size

For the correct tubing size, follow the specification for the condenser/heat pump.

### Special Instructions

This coil comes equipped with a check style flowrator for refrigerant management. For most installations with matching applications, no change to the flowrator piston is required. However, in mix-matched applications, a flowrator piston

change may be required. See the Goodman® piston kit chart or consult your local distributor for details regarding mix-matched piston sizing. If the mix-match application requires a different piston size, change the piston in the flowrator on the indoor coil before installing the coil and follow the procedure shown below.

1. Loosen the 13/16 nut **1 TURN ONLY** to allow high pressure tracer gas to escape. No gas indicates a possible leak.
2. After the gas has escaped, remove the nut and discard the black or brass cap.
3. Remove the check piston to verify it is correct and then replace the piston. See piston kit chart in instructions.
4. Use a tube cutter to remove the spin closure on the suction line.
5. Remove the tailpiece clamped to the exterior and **slide the 13/16 nut into place.**
6. Braze tailpiece to the line set liquid tube.

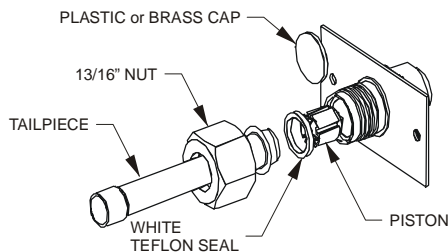

Figure 1

7. Insert the suction line into the connection, slide the insulation and the rubber grommet at least 18" away from the braze joint. Braze suction line.
8. **AFTER THE TAILPIECE HAS COOLED**, confirm position of the white Teflon® seal and hand tighten the 13/16 nut.
9. Torque the 13/16 nut to 10-30 ft-lbs. or tighten 1/6 turn.



## CAUTION

Excessive torque can cause orifices to stick. Use the proper torque settings when tightening orifices.

10. Replace suction line grommet and insulation.

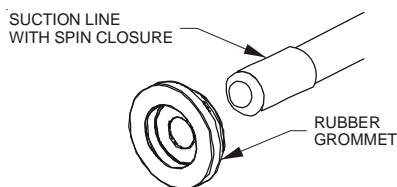

Figure 2

## Downflow Conversion

**NOTE: ATUF models should not be converted to Downflow applications.**

“D” nomenclature models are factory equipped for “Dedicated Downflow” operation and no field conversion is required.

Conversion to downflow **MUST** be performed in an area that allows access to all sides prior to placing the air handler in its final location. To prevent the evaporator coil pan from “sweating” the DPI accessory insulation kit is to be used when performing this conversion. **NOTE:** The DPI kit is not supplied with this product and is to be purchased separately. See **Table 7** for the correct DPI kit.

ARUF/ARPF	AEPF/ASP	Insulation Kit
1729 1824	N/A	DPI18-30/20
3030 1931 3636	1830	DPI36-42/20
3642 3743 4860	3036 4260	DPI48-61/-20

Table 7

Refer to **Figures 3 through 5** for the location of the components referenced in the following steps. **Figure 3** illustrates the new installation location for the removed components.

1. Before inverting the air handler, remove all access panels, the coil rear channel bracket, and the filter close-off panel.
2. Remove the evaporator coil and the horizontal drain pan. Discard horizontal drain pan.
3. Install the provided plastic plug into the vacated access panel.
4. Remove the two (2) zee coil support brackets and insulation retaining brackets.
5. Remove the tie bracket.
6. Install the DPI Insulation Kit onto the bottom of the drain pan.

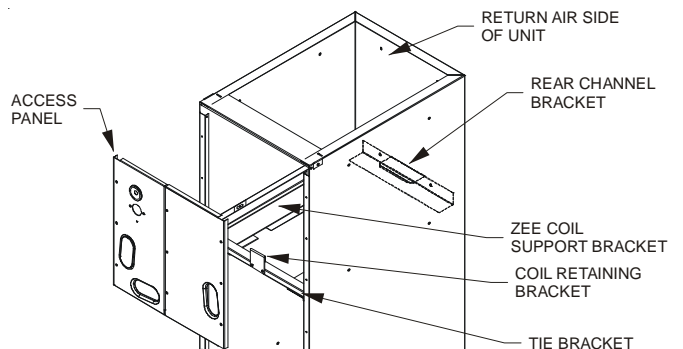

**NOTE: The filter provision is not applicable in THIS downflow application.**

Figure 3

7. Install the zee coil supports and the wrapper stiffeners.
8. Install the tie bracket.
9. Install the rear channel bracket.
10. To prevent possible condensate “blow off” the insulation retainers are to be laid into the evaporator coil pan

as shown in **Figure 4**.

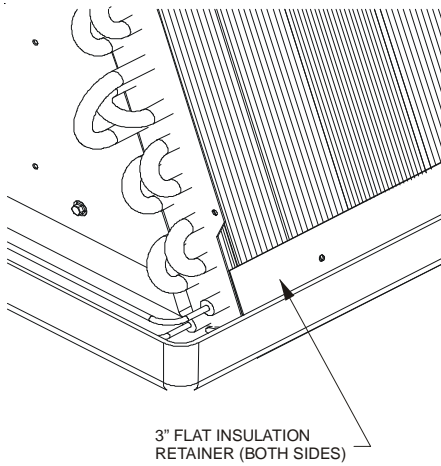

**Figure 4**

To complete the conversion, slide the evaporator coil into the chassis and attach the three (3) access panels. (**Figure 5**).

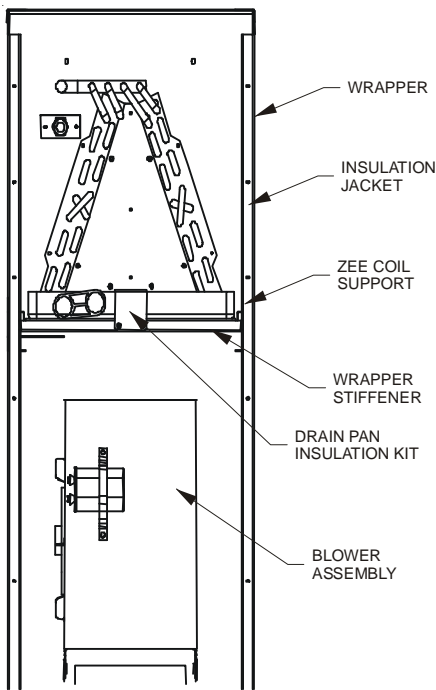

**Figure 5**

### Horizontal Conversion

Dedicated Downflow models are not suitable for horizontal application and must not be used for this type of installation. The only field modification required for conversion to "Horizontal Right-Hand" is the removal of the plastic knockouts in the horizontal panel drain connections. To prevent the horizontal drain pan from sweating in high humidity applications, it is recommended that a DPIH insulation accessory kit be used. **NOTE:** The DPIH insulation kit is not supplied with this product and should be purchased separately. See **Table 8** for the correct DPIH kit.

ATUF	ARUF/ARPF	AEPF/ASPF	Insulation Kit
1824	1729 1824	N/A	DPIH18-32
3030 1931 3636	3030 1931 3636	1830	DPIH36-42
3642 3743 4860	3642 3743 4860	3036 4260	DPIH48-61

**Table 8**

The following describes converting to "Horizontal Left-Hand". Conversion to downflow **MUST** be performed in an area that allows access to all sides prior to placing the air handler in its final location (**See Figure 6**).

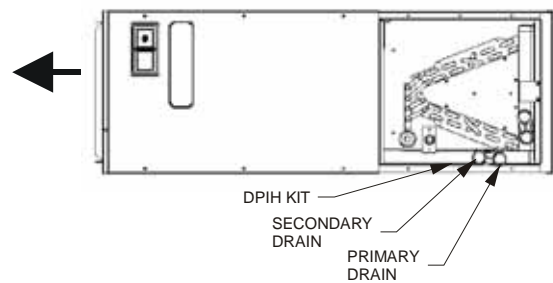
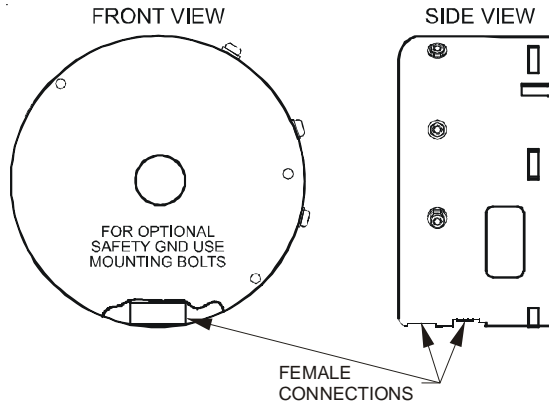

**Figure 6**

1. Remove the (3) air handler access panels.
2. Remove the "J" shaped bracket that retains the evaporator coil.
3. Remove the flowrator from the lower left side access panel and slide out the evaporator coil and horizontal drain pan.
4. Remove the gasket from the horizontal pan drain connections.
5. Remove the oval shaped plastic plug from the left side access panel. Remove the oval shaped rubber gasket seal from the lower right side access panel.
6. The drain connections for the horizontal pan are sealed with a thin coating of plastic. Carefully knock out this plastic seal with a screwdriver and hammer. **Note: The upper drain will become the secondary drain which is mandatory in many municipalities .**
7. Install the plastic plug removed in step 5 to the right side lower access panel and the oval shaped rubber gasket to the lower left access panel.
8. Reinstall the evaporator coil with the horizontal panel on the left side. Note: Push the assembly completely to the rear to ensure the engagement of the upflow pan with the rear channel bracket.
9. Install the "J" bracket (removed in step 2) to support the upflow pan to the tie channel.
10. Attach all panels and the metering device.

## AEPF MOTOR ORIENTATION

If the unit is in the upflow position, there is no need to rotate the motor. If the unit is in the downflow position, loosen motor mount and rotate motor as shown in **Figure 7**. Be sure motor is oriented with the female connections on the casing down. If the motor is not oriented with the connections down, water will collect in the motor and may cause premature failure.



**Figure 7**  
(AEPF Motor Orientation)

## Condensate Removal

The drain pan has a primary and secondary drain connection (Figure 8). Condensate removal is performed by attaching a 3/4" PVC pipe to the evaporator coil pan and terminated in accordance with local or state Plumbing/HVAC codes. The installation must include a "P" style trap that is located as close as is practical to the evaporator coil. Exercise caution not to overtighten the drain connection(s) in order to prevent possible damage to the evaporator drain pan. See **Figure 8** for details of a typical condensate line "P" trap.

To prevent potential sweating and dripping on to finished space, it may be necessary to insulate the condensate drain line located inside the building. Use Armaflex® or similar material.

Installations that are above a finished ceiling may require a field supplied auxiliary drain pan. Consult local codes on this requirement.

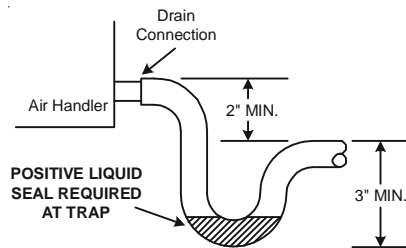

**Figure 8**

Use of a condensate removal pump is permitted when necessary. This condensate pump should have provisions for shutting off the control voltage should a blocked drain occur. A trap must be installed between the unit and the condensate pump.

**IMPORTANT NOTE:** The evaporator coil is coated with oils that may dissolve styrofoam and certain types of plastics. Therefore, a removal pump or float switch must not contain any of these materials.

**Tip:** Priming the "P" trap may avoid improper draining at the initial installation and at the beginning of the cooling season.

## ACHIEVING 2% LOW LEAKAGE RATE

Ensure that the Neoprene gasket with PSA remains intact on all surfaces that the access panels are secured to. These surfaces are the entire length of the wrapper and areas between the upper tie plate, upper and lower access panels. Be sure that upper access panel breaker insert gasket is intact and also flowrator gasket is installed on the lower access panel. An additional drain hole cover is required.

## ATUF/ARUF/ARPF/ADPF MOTOR

(Motor Speed Adjustment)

The motors in all ATUF, ARUF, ARPF and ADPF motors are multi-speed PSC motors. The color of the wire coming from the motor to the "COM" terminal on the control board defines in which speed the motor will operate. The black wire represents high speed, the red wire represents low speed, and the blue wire (select models only) represents medium speed. To change speeds, remove the wire attached to the "COM" terminal on the control board, and swap it with the wire (on terminal "M1" or "M2") with the color that will give the desired speed.

**NOTE:** In some models, not all speed taps are allowable for certain electric heat applications. Refer to air handler Series and Ratings plate for minimum speed.

## AEPF Motor

This section references the operation characteristics of the AEPF model motor only. The ECM control board is factory set with dipswitch #4 in the "ON" position and all other dipswitches in the "OFF" position. **For most applications this setting is to be changed according to the electric heat size and the outdoor unit selection.**

The AEPF product uses a General Electric ECM™ motor. This motor provides many features not available on the traditional PSC motor. These features include:

- Improved Efficiency
- Constant CFM
- Soft Start and Stop
- Improved Humidity Control

## Motor Speed Adjustment

Each ECM™ blower motor has been preprogrammed for operation at 4 distinct airflow levels when operating in Cooling, H.P. Heating, Backup Heating (Electric Heating), and Backup + H.P. Heating. Each mode has 4 levels to deliver different Air Flow CFM [L/s]. The adjustment is performed by changing the dipswitch(es) either to an "OFF" or "ON" position.

## Dipswitch Functions

The AEPF air handler motor has an electronic control that contains an eight (8) position dip switch. The function of these dipswitches are shown in **Table 9**.

Dipswitch Number	Function
1	Electric Heat
2	
3	N/A
4	Indoor Thermostat
5	Cooling & Heat Pump CFM
6	
7	CFM Trim Adjust
8	

Table 9

### CFM Delivery

Tables 10-Electric Heat and 11-Cooling/Heat Pump show the CFM output for dipswitch combinations 1-2, and 5-6.

Model	Switch		Emergencny (Electric) Heat	Heat Pump w/Backup Heat
	1	2		
AEPF1830	OFF	OFF	1100	1210
	ON	OFF	850	935
	OFF	ON	700	775
AEPF3036 and AEPF4260	OFF	OFF	2050	2150
	ON	OFF	1750	1835
	OFF	ON	1600	1680
	ON	ON	1200	1260
	ON <sup>1</sup>	ON	1020	1020

<sup>1</sup> 7-8 shall be OFF-ON for 2.5 Ton applications

Table 10

Model	Switch		Nominal Cooling Tonnage	CFM
	5	6		
AEPF1830	OFF	OFF	2 ½	1100
	ON	OFF	2	800
	OFF	ON	1 ½	600
AEPF3036 and AEPF4260	OFF	OFF	5	1800
	ON	OFF	4	1580
	OFF	ON	3 ½	1480
	ON	ON	3	1200

Table 11

### Thermostat “Fan Only Mode”

During “Fan Only Mode” operation, the CFM output is 30% of the cooling setting.

### CFM Trim Adjust

Minor adjustments can be made through the dip switch combination of 7-8. The following Table 12 shows the switch position for this feature.

CFM	Switch 7	Switch 8
+10%	ON	OFF
-15%	OFF	ON

Table 12

### Humidity Control

When using a Humidistat (normally closed), cut jumper PJ6 on the control board. The Humidistat will only affect cooling airflow by adjusting the Airflow to 85%.

### Two Stage Heating

When using staged electric heat, cut jumper PJ4 on the control board.

### ASPF Motor

The ASPF air handler features a General Electric energy saving X13 motor. The X13 motor is a constant torque motor with very low power consumption. The motor is energized by 24 VAC. Adjust the CFM by changing the 24 VAC leads to the desired speed on the terminal block.

The ASPF motor blower speed is programmed to deliver adequate airflow at rated external static pressure and with 60 second off time delay. For details, refer to the specification sheet applicable to your model.

### CFM Delivery

Table 13 show the CFM speed tap settings for the ASPF.

ASPF1830	
Factory Speed Setting T4	
CFM	SETTING
650	T1
800	T2
900	T3
1050	T4
1150	T5

ASPF3036	
Factory Speed Setting T4	
CFM	SETTING
800	T1
900	T2
1050	T3
1250	T4
1350	T5

ASPF4260	
Factory Speed Setting T4	
CFM	SETTING
1250	T1
1400	T2
1550	T3
1800	T4
2000	T5

Table 13

### Thermostats

**NOTE:** Second Stage heat can be accomplished by multi-stage heating thermostat or the addition of an outdoor thermostat as shown in Figures 11 and 12.

Goodman® part number CHT18-60 is a single-stage cool and single-stage heat thermostat.

Goodman® part number HPT18-60 is a single-stage cool, two-stage heat pump thermostat. The first stage is heat pump heating and the second stage is optional electric heat.

If additional features are desired, such as digital or programmable capabilities, these thermostats are commercially available. Follow the thermostat manufacturer's instruction for installation.

### Start-Up Procedure

- Prior to start-up, ensure that all electrical connections are properly sized and tightened.
- All panels must be in place and secured. For Air Tight application, neoprene gasket must be positioned at prescribed locations to achieve 2% leakage.
- Tubing must be leak free.
- Unit should be elevated, trapped and pitched to allow for drainage.
- Low voltage wiring is connected.
- Auxiliary drain is installed when necessary and pitched to allow for drainage.
- Drain pan and drain tubing has been leak checked.
- Return and supply ducts are sealed.
- Unit is elevated when installed in a garage or where flammable vapors may be present.
- Unit is protected from vehicular or other physical damage.
- Return air is not obtained from any areas where there may be objectionable odors, flammable vapors or products of combustion such as carbon monoxide (CO), which may cause serious personal injury or death.

### Regular Maintenance



#### WARNING

##### HIGH VOLTAGE!

Disconnect ALL power before servicing or installing this unit. Multiple power sources may be present. Failure to do so may cause property damage, personal injury or death.



The only item to be maintained on a regular basis by the user is the circulating air filter(s). Filter should be cleaned or replaced regularly. A certified service technician must perform all other services.

THIS PAGE LEFT INTENTIONALLY BLANK

# THERMOSTAT WIRING

**NOTE:** DO NOT USE THESE DIAGRAMS FOR AEPF MODELS. SEE SUPPLEMENTAL INSTALLATION AND OPERATING INSTRUCTIONS FOR AEPF MODELS.

**WARNING** **HIGH VOLTAGE!** DISCONNECT ALL POWER BEFORE SERVICING. MULTIPLE POWER SOURCES MAY BE PRESENT. FAILURE TO DO SO MAY CAUSE PROPERTY DAMAGE, PERSONAL INJURY OR DEATH.

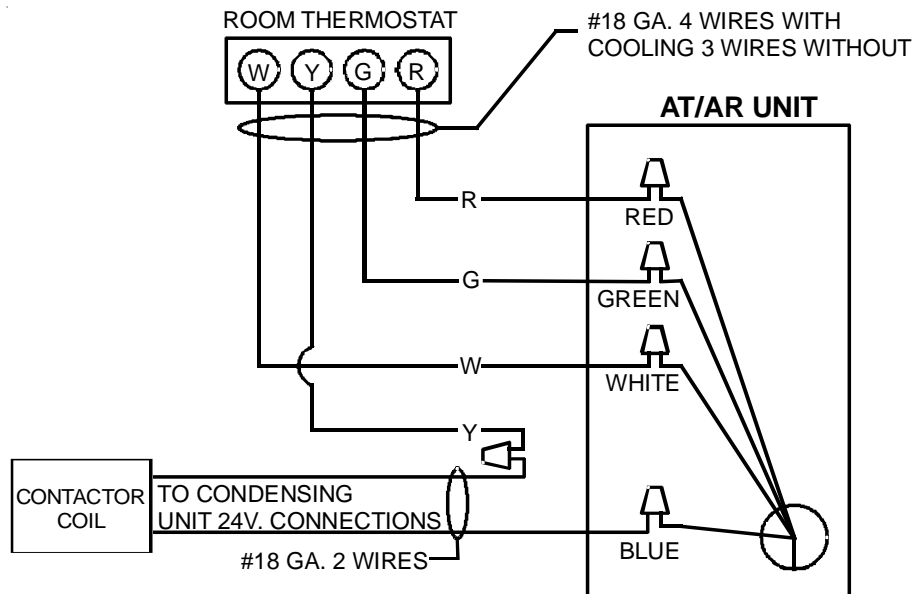

Figure 9 - Low Voltage Wiring Diagram for Cooling Unit with optional heat kit 10kW and below

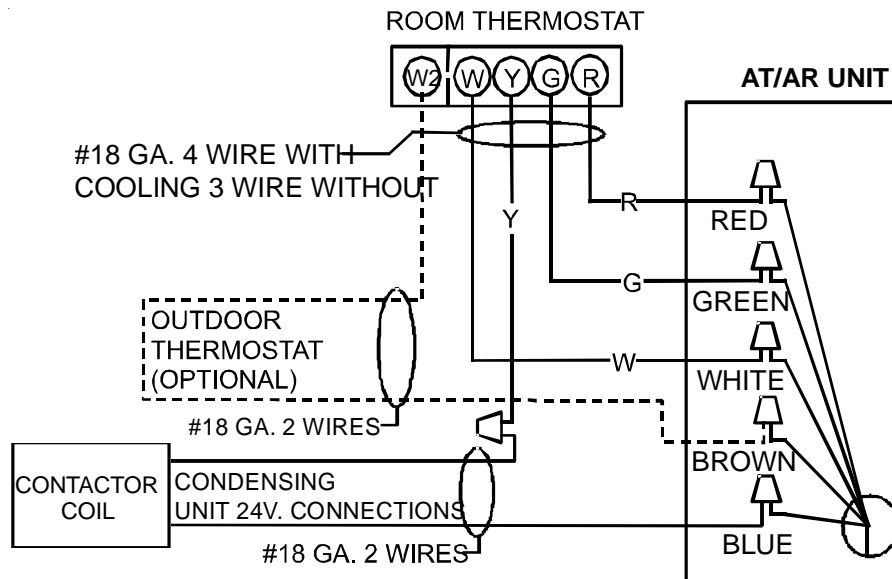

Figure 10 - Low Voltage Wiring Diagram for Cooling Unit with optional heat kit 15kW and above

Wiring Diagrams are subject to change without notice.



**WARNING**

**HIGH VOLTAGE! DISCONNECT ALL POWER BEFORE SERVICING. MULTIPLE POWER SOURCES MAY BE PRESENT. FAILURE TO DO SO MAY CAUSE PROPERTY DAMAGE, PERSONAL INJURY OR DEATH.**



ATUF/ARUF/ARPF/ADPF

18-60

10 KW & BELOW

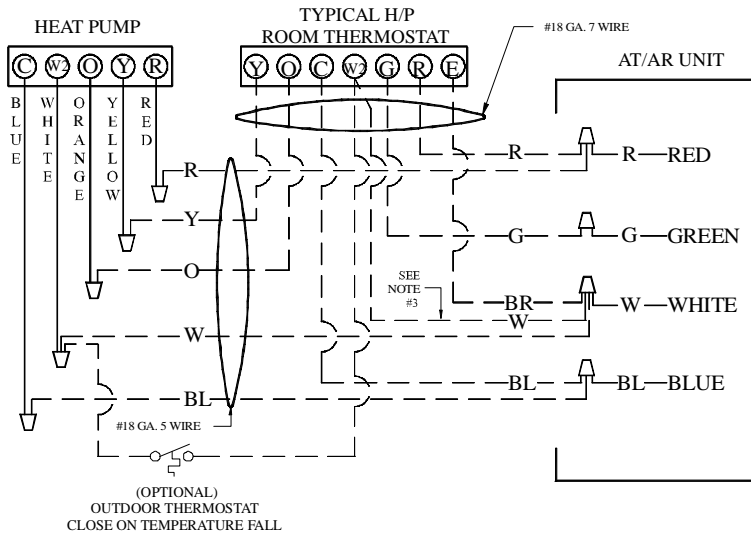

FIGURE 11

#18 GA. 6 WIRE NEEDED WHEN OT IS USED

ATUF/ARUF/ARPF/ADPF

18-60

ABOVE 10 KW

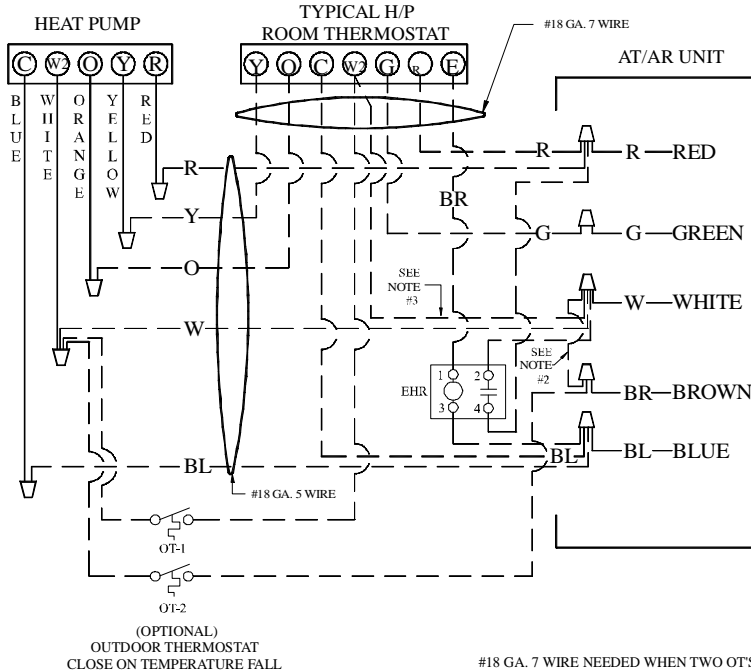

FIGURE 12

#18 GA. 7 WIRE NEEDED WHEN TWO OT'S ARE USED

**NOTES:**

- 1) OUTDOOR THERMOSTAT (OT-1) SHOULD BE THE FIRST TO CLOSE AND THE LAST TO OPEN.
- 2) CONNECT WHITE AND BROWN WIRES FROM AIR-HANDLER TOGETHER IF OT-2 IS NOT USED.
- 3) REMOVE WIRE WHEN USING OUTDOOR THERMOSTAT

**NOMENCLATURE**

- OT ---OUTDOOR THERMOSTAT (OPTIONAL)  
 EHR -EMERGENCY HEAT RELAY (OPTIONAL)

**COLOR CODES**

- R --RED  
 Y --YELLOW  
 BL-BLUE  
 BR-BROWN  
 O --ORANGE  
 W --WHITE  
 G --GREEN

**IMPORTANT:** If outdoor thermostat is not used, tie white and brown wires from Air Handler together

**Wiring Diagrams are subject to change without notice.**

## ASPF THERMOSTAT CONNECTIONS

The following composite wiring diagrams detail various configurations in which the ASPF air handlers can be used. Examples include single-stage cooling and heat pump with single or two-stage electric heating. All these configurations can be applied with convenient connections to outdoor thermostat applications.

The following sections will be detailed:

- Single-Stage Cooling (GMC Thermostat Part #CHT18-60 or equivalent.)
- Heat Pump (GMC Thermostat Part #18-60 or equivalent)

Each diagram details the connections between room thermostat and ASPF air handlers, and the connections between the ASPF air handlers and the Condensing Unit (or Heat Pump) with optional connections to Outdoor Thermostats. For each configuration, refer to the explanation of the proper jumper(s) to remove for the corresponding blower speed that will result in the programmed ECM™ motor.

**IMPORTANT: WHEN MATCHING THE ASPF AIR HANDLERS TO A SINGLE STAGE COOLING UNIT OR HEAT PUMP, REMEMBER TO CONNECT THE “Y/Y2” THERMOSTAT CONNECTION ON THE VARIABLE SPEED BOARD (VSTB) TO THE THERMOSTAT. CONNECTING “Y1” WILL RESULT IN FIRST STAGE COOLING BLOWER SPEED AND MAY CAUSE THE CONTACTOR TO CHATTER.**

An equivalent thermostat can be used in place of the Goodman thermostat part number. The GMC thermostats that listed are mercury type thermostats.

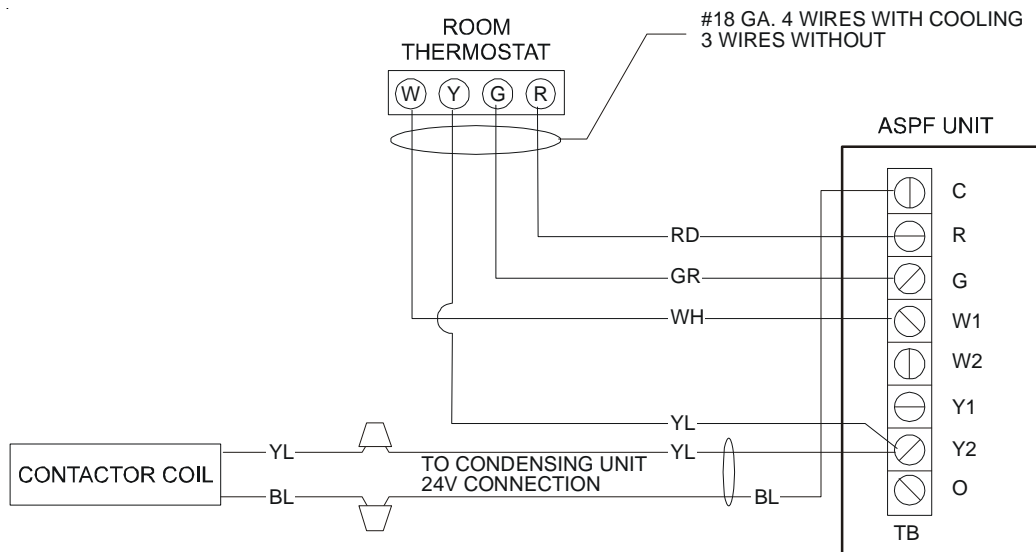

COOLING UNIT WITH OPTIONAL HEAT KITS OF 10 kW AND BELOW

### NOTES:

- 1) OUTDOOR THERMOSTAT (OT-1) SHOULD BE THE FIRST TO CLOSE AND THE LAST TO OPEN.
- 2) JUMPER W1 AND W2 TOGETHER IF OT-2 IS NOT USED.
- 3) REMOVE WIRE WHEN USING OUTDOOR THERMOSTAT.

### NOMENCLATURE:

- OT - OUTDOOR THERMOSTAT (OPTIONAL)  
EHR - EMERGENCY HEAT RELAY (OPTIONAL)

### COLOR CODES

- RD - RED  
YL - YELLOW  
BL - BLUE  
BR - BROWN  
OR - ORANGE  
WH - WHITE

Wiring is subject to change, always refer to the wiring diagram on the unit for the most up-to-date wiring.

**WARNING** HIGH VOLTAGE! DISCONNECT ALL POWER BEFORE SERVICING. MULTIPLE POWER SOURCES MAY BE PRESENT. FAILURE TO DO SO MAY CAUSE PROPERTY DAMAGE, PERSONAL INJURY OR DEATH.

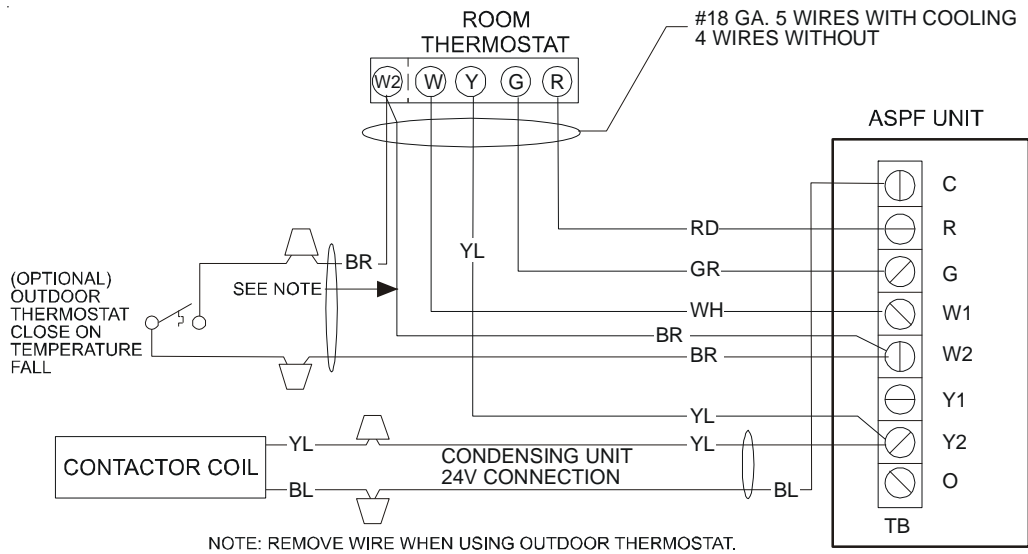

**COOLING UNIT WITH OPTIONAL HEAT KITS OF 15 kW AND ABOVE AND ROOM THERMOSTAT WITH TWO STAGES OF HEAT**

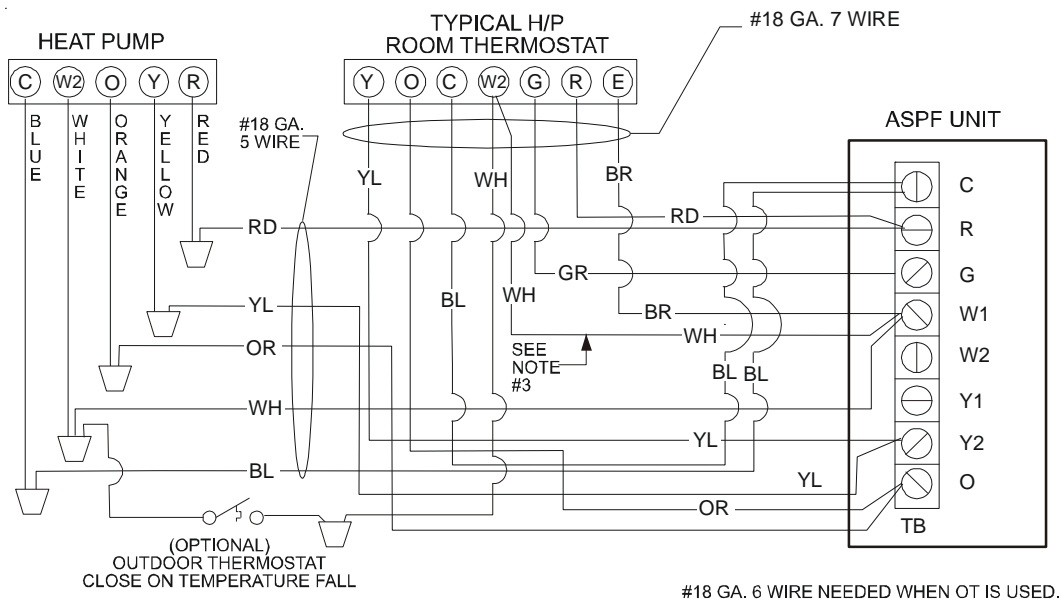

**HEAT PUMP UNIT WITH OPTIONAL HEAT KITS OF 10 kW AND BELOW**

**NOTES:**

- 1) OUTDOOR THERMOSTAT (OT-1) SHOULD BE THE FIRST TO CLOSE AND THE LAST TO OPEN.
- 2) JUMPER W1 AND W2 TOGETHER IF OT-2 IS NOT USED.
- 3) REMOVE WIRE WHEN USING OUTDOOR THERMOSTAT.

**NOMENCLATURE:**

- OT - OUTDOOR THERMOSTAT (OPTIONAL)
- EHR - EMERGENCY HEAT RELAY (OPTIONAL)

**COLOR CODES**

- RD - RED
- YL - YELLOW
- BL - BLUE
- BR - BROWN
- OR - ORANGE
- WH - WHITE

Wiring is subject to change, always refer to the wiring diagram on the unit for the most up-to-date wiring.



**WARNING**

**HIGH VOLTAGE! DISCONNECT ALL POWER BEFORE SERVICING. MULTIPLE POWER SOURCES MAY BE PRESENT. FAILURE TO DO SO MAY CAUSE PROPERTY DAMAGE, PERSONAL INJURY OR DEATH.**

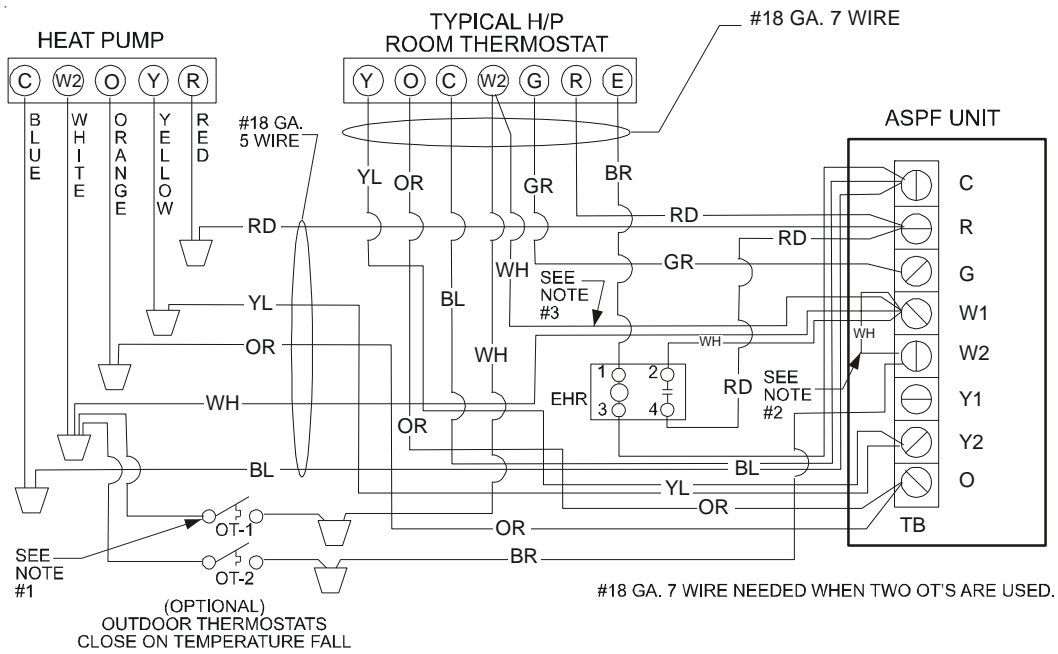

**NOTES:**

- 1) OUTDOOR THERMOSTAT (OT-1) SHOULD BE THE FIRST TO CLOSE AND THE LAST TO OPEN.
- 2) JUMPER W1 AND W2 TOGETHER IF OT-2 IS NOT USED.
- 3) REMOVE WIRE WHEN USING OUTDOOR THERMOSTAT.

**NOMENCLATURE:**

- OT - OUTDOOR THERMOSTAT (OPTIONAL)  
 EHR - EMERGENCY HEAT RELAY (OPTIONAL)

**COLOR CODES**

- RD - RED  
 YL - YELLOW  
 BL - BLUE  
 BR - BROWN  
 OR - ORANGE  
 WH - WHITE

**Wiring Diagrams are subject to change without notice.**

**WARNING** HIGH VOLTAGE! DISCONNECT ALL POWER BEFORE SERVICING. MULTIPLE POWER SOURCES MAY BE PRESENT. FAILURE TO DO SO MAY CAUSE PROPERTY DAMAGE, PERSONAL INJURY OR DEATH.

**NOTE: This is not applicable to ASPF models.**

**ELECTRONIC BLOWER TIME DELAY RELAY**

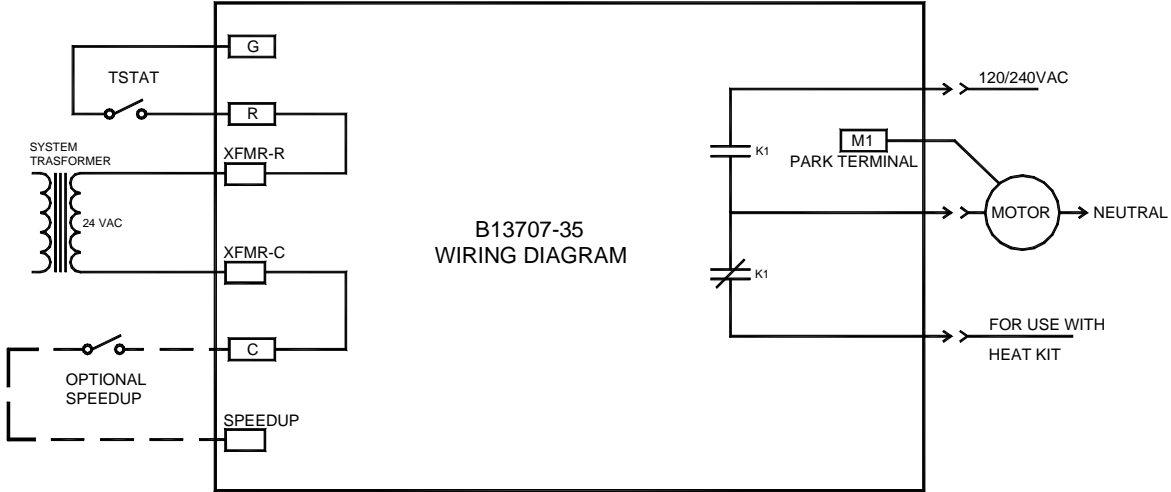

The Electronic Blower Time Delay Relay provides power to the blower motor with a delay of 7 seconds after 24VAC is applied to “G”. After 24VAC is removed from “G”, the blower motor output is de-energized after a delay of 65 seconds.

Normal Time Delays	60Hz	50Hz
Turn On Delay	7.0 SEC.±1%	8.4 SEC. ±1%
Turn Off Delay	65.0 SEC.±1%	78.0 SEC. ±1%

**Field test mode:** Shorting the “speedup” quick connect to “C” decrease times as follows:

Speedup Times	60Hz	50Hz
Turn On Delay	3.0 SEC.±1%	3.6 SEC. ±1%
Turn Off Delay	5.0 SEC.±1%	6.0 SEC. ±1%

Field test mode is cancelled when the “speedup” quick connect to “C” short is removed.

Goodman Manufacturing Company, L.P.  
5151 San Felipe, Suite 500, Houston, TX 77056  
[www.goodmanmfg.com](http://www.goodmanmfg.com)  
© 2004-2008 Goodman Manufacturing Company, L.P.