



Central Air Conditioning

SERVICE MANUAL



Models

HB2400VD1M20

HB3600VD1M22

HB4800VD1M22

HB6000VD1M22

HB6000VD1M22(-E)

Part number:
AC-8888-176

● Features

- High efficiency design
- Split-packaged design
- Optional electric heater
- Fully insulated and durable cabinet
- Easily filter replacement
- Convenient for installation and maintenance

CONTENTS

1. DESCRIPTION OF PRODUCTS & FEATURES.....	3
2. PHYSICAL AND ELECTRICAL SPECIFICATIONS.....	4
3. SAFETY PRECAUTION.....	5
4. ELECTRICAL CONTROL DEVICES.....	5
5. APPLICATION.....	5
6. INSTALLATION INSTRUCTIONS.....	7
7. WIRING DIAGRAMS.....	17

1. DESCRIPTION OF PRODUCTS & FEATURES

1.1 Air conditioning

This manual discusses ‘split’ central air conditioning and indoor coils. “Split” central air condition system refers to the physical location of major air conditioning components. The split system air conditioning are manufactured to standards of quality and performance.They are 13 SEER(Seasonal Engery Efficiency Ratio) which meet or exceed the standards imposed by efficiency legislated and therefore represent both good value today and for years to come. The current air conditioning system use scroll and reciprocating compressors. This gives the air conditioning a durable compressor which needs less external protection, while increasing the unit efficiency in cooling mode.

1.2 Nomenclature for model number

Example

H	B	60	00	V	D	1	M	22	E
Haier	Blower unit	Nominal capacity in (1000) Btu/h	Electric heater	Electric Designation	Coil code	Design series	Airflow configuration	Unit Width(in.)	Continuation
Brand symbol	B:Blower unit C:Evaporator W:Wall moun- ted unit	24: 24000BTU/h 30: 30000BTU/h	00: No; 05: 5KW; 08: 8KW; 10:10KW	Y:575V-3Ph-60Hz; V:208/230V-1Ph- 60Hz; C:208/230V-3Ph- 60Hz; D:460V-3Ph- 60Hz; A:115V,1 Ph,60Hz	A:10 SEER A/C coil D:13 SEER A/C coil E:14 SEER A/C coil	1: 1st Generation; 2: 2nd Generation;	M:Multi- direction V:Vertical H:Horizontal	17:17"[432] 20:20"[497] 22:22"[559] 25:25"[625]	P: Powder paint E: EC motor

Table 1-1

2. PHYSICAL AND ELECTRICAL SPECIFICATIONS

HB-D AIR HANDLER SPECIFICATIONS

ITEM	HB2400VD1M20	HB3600VD1M22	HB4800VD1M22	HB6000VD1M22	HB6000VD1M22-E
Model Status	New Model	New Model	New Model	New Model	New Model
Performance					
Airflow Rate (CFM)	900	1240	1650	1800	1850
Noise level (Semi-Anechoic)	55	60	60	62	62
Electrical					
Voltage - Phase - Frequency (Hz)	208/230-1-60	208/230-1-60	208/230-1-60	208/230-1-60	208/230-1-60
Minimum Circuit Amps	1.2	2.5	3.3	4.4	5.0
Maximum Overload Amps	15	15	15	15	15
Fan Motor					
RLA (Rated Load Amps)	0.9	2.0	2.6	3.5	4.0
Rated House Power (hp)	1/8	1/3	1/2	1/2	3/4
Nominal RPM	1075	1027	1000	988	1000
Fan					
Dia.--width(In)	9--8	9--8	10--8	10--10	10--10
Fan Material	Zinc-Coated Steel	Zinc-Coated Steel	Zinc-Coated Steel	Zinc-Coated Steel	Zinc-Coated Steel
Evaporator coil					
Number of Rows	3	3	3	4	4
Tube spacings (V x H) (In)	1 x 0.85	1 x 0.85	1 x 0.85	1 x 0.85	1 x 0.85
Fins per Inch - FPI	15.5	17	17	17	17
Fin Type	Lanced, Coated	Lanced, Coated	Lanced, Coated	Lanced, Coated	Lanced, Coated
Tube OD and Type	3/8" Grooved	3/8" Grooved	3/8" Grooved	3/8" Grooved	3/8" Grooved
Gross Finned Face Area (Sq Ft)	4.2	5.9	7	7	7
Number of Circuits (In/Out)	6/6	6/6	6/6	8/8	8/8
Exterior Appearance					
Cabinet color	Unpainted, grey	Unpainted, grey	Unpainted, grey	Unpainted, grey	Unpainted, grey
Service panel	Unpainted, grey	Unpainted, grey	Unpainted, grey	Unpainted, grey	Unpainted, grey
Features					
Multi-Position, Convertible	Yes	Yes	Yes	Yes	Yes
Galvanized Steel Cabinet	Yes	Yes	Yes	Yes	Yes
Coil Design	Haier Enhanced Coil	Haier Enhanced Coil	Haier Enhanced Coil	Haier Enhanced Coil	Haier Enhanced Coil
Nitrogen holding charge	Yes	Yes	Yes	Yes	Yes
Easy Service Access	Yes	Yes	Yes	Yes	Yes
Corrosion Resistant Outside Screws	Yes	Yes	Yes	Yes	Yes
Accessories					
Plastic Filter	Optional	Optional	Optional	Optional	Optional
Subsidiary drain pan	Yes	Yes	Yes	Yes	Yes
Heater	optional	optional	optional	optional	optional
Dimensions and Installation					
Unit	Height	47.5	49 1/2	56 1/4	56 1/4
Dimensions (inches)	Width	20	21 3/4	21 3/4	21 3/4
	Depth	22	24	24	24
Minimum inlet and outlet dimension	18 1/2*18 /12*10 /12	20 2/5*22 4/5 / 19 5/8*12	20 2/5*22 4/5 / 19 5/8*12	20 2/5*22 4/5 / 19 5/8*12	20 2/5*22 4/5 / 19 5/8*12
Refrigerant Line	Liquid Line Dimension (In)	3/8	3/8	3/8	3/8
	Vapor Line Dimension (In)	3/4	7/8	7/8	7/8
Weight (lbs)					
Net		117	156	172	198
Shipping		134	167	192	216
Agency Approvals					
Performance Certification		ARI	ARI	ARI	ARI
Safety Approvals		UL/CUL	UL/CUL	UL/CUL	UL/CUL
Shipping					
Carton	Height	48 3/5	51 5/8	58 3/8	58 3/8
Dimensions (In)	Width	21 1/4	24 1/2	24 1/2	24 1/2
	Depth	27 3/5	28 3/4	28 3/4	28 3/4
Cubic Volume (Cu. Ft)		16.5	21.1	23.8	23.8
Warranty(Haier Brand Only)					
Labor		5	5	5	5
Parts		5	5	5	5

3.SAFETY PRECAUTIONS

CAUTION: please read all instructions prior to installing, operating, maintaining or repairing the product.

WARNING: THE MANUFACTURER'S WARRANTY DOES NOT COVER DAMAGE TO CAUSED BY THE USE OF ANSUTHORIZED COMPONENTS OR ACCESSORIES, THE USE OF SUCH UNAUTHORIZED COMPONENTS OR ACCESSORIES MAY ENDANGER LIFE AND PROPERTY. THE MANUFACTURER DISCLAIMS ANY RESPONSIBILITY FOR SUCH LOSS OR INJURY RESULTING FROM THE USE OF SUCH UNAUTHORIZED COMPONENTS OR ACCESSORIES

- Always use industry-recognized service practices in the maintenance, adjustment and repair of the products covered in this manual.
- Always wear safety glasses when handling refrigerant and peforming brazing operations.
- Follow the manufacturer's instructions when making repairs, installing replacement parts and performing system maintenance.
- Use only authorized factory parts.

4.ELECTRICAL CONTROL DEVICES

THERMOSTATS

Thermostats are the most obvious control in the air conditioning system because these controls are accessible by the consumer. Contact your local distributor for information on part numbers of various manual changeover, auto changeover and set-back thermostats or see the thermostat and subbase selection information found in the wiring diagram booklet.

In the cooling mode, the thermostat calls for cooling by energizing the compressor contactor and the indoor blower control. The indoor blower can operate continuously by setting the thermostat subbase fan switch to the "ON" position.

RELAYS

Relays provide a method for control switching. Relays may switch either low(24VAC) or line voltage. Generally relays used in air conditioning use 24VAC coils. Contact voltage may be either low or line voltage.

HEATER CONTACTOR

The coil uses 24 volts but the contacts carry line voltage .The heater contactor is a large relay, which controls the heater.

OVERLOADS AND LIMITS

There are similar overloads in the indoor air handling portion with the electric resistance heaters. The indoor blower motor has an internal overload. The electric elements use two types of protectors, both replaceable. Some electric heat sections use fusible links. They are a one time over-temperature protector and must be replaced upon opening. Limit controls are thermal discs that automatically reset. Normally, limit controls open and stop the temperature rise before the fusible links open.

NOTE: Never disconnect or wire around a safety device. First determine why it opened, then replace it with a properly rated part.

5. APPLICATION

Before specifying any air conditioning equipment, a survey of the structure and a heat gain calculation must be made. A heat gain calculation involves identifying all surfaces and openings that gain heat from the surrounding air and quantifying that heat gain. The heat calculation also calculates the extra heaty load caused by sunlight and by humidity removal. These factors must be considered before selection an air conditioning system to provide year round comfort. The Air Conditioning Contractors of America (ACCA) J Manual method of load calculation is one recognized procedure for determining the cooling load.

The cooling load calculation determines the unit size. There are two capacities that enable the equipment to provide comfort. The first is sensible capacity. Sensible heat is the heat energy measured on the dry bulb thermometer.

The second form of heat is called latent heat. This is heat held by the moisture in the air. Removing this moisture does not affect a thermometer. However, removing the latent heat in the air greatly increase comfort. A properly sized unit removes both forms of heat, producing a comfortable conditions, An oversized system cycles on and off quickly and does not properly remove humidify, producing uncomfortable. The indoor and outdoor equipment combination should be matched by the manufacturer and based on engineering data.

After the proper equipment combination has been selected, satisfying both sensible and latent conditioning requirements, the system must be properly installed. Proper installation with carefully distributed air through adequate duct work will provided a comfortable living space.

There are several factors that installers must consider.

- Outdoor unit location
- Proper equipment evacuation
- Outdoor unit refrigerant charge
- Indoor unit air flow
- Indoor unit blower speed
- Supply and return air duct design and sizing
- System air balancing
- Diffuser and return air grille location and sizing

The air distribution system has the greatest effect. On the quality of the installation and the owner satisfaction, the duct system is totally in the responsibility of the contractor. These are numerous thchnical associations and reference that recommend correct procedures.

The correct air quantity is critical for correct air conditioning system. Proper operation, efficiency, compressor life and humidity control depend on the correct balance between indoor load and outdoor unit capacity. High indoor air flow reduces system dehumidification capacity, and can leave the space humid and uncomfoltable. Low indoor air flow reduces total capacity, and can causes coil icing. Improper air balance will affect system performance and customer's satisfaction and can cause premature component failure.

Air conditioning requires a specified air flow. Each ton of air conditioning requires 400 cubic feet of air per minute (**400CFM/TON**).

Duct design and construction should be done with care. System performance can be lowered dramatically through bad planning or workmanship. In cooling, a hot attic can cause a temperature gain of 3° in the return duct and 4° in the supply duct. This can reduce the cooling capacity of an air conditioning system by as much as 30%.This means a loss of almost one ton of cooling capacity from a three ton system.

Air leakage of only 3% in a return duct can cause a 5% loss in system capacity. 3% leakage on a three ton system is only 30 CFM. Two or three unsealed joints can cause a leak of this size. Sealing the return and supply ducts result in full system capacity and lower operating costs.

Effective duct insulation is essential to prevent loss of capacity and sweating ducts in the cooling mode. Duct systems installed in the conditioned space can be left uninsulated , but a dense 1/2" fiberglass duct liner reduces blower and air noises, and prevents sweating ducts when humidity levels are high.

Supply and return duct systems in attics and crawl spaces require a minimum 1" of dense duct liner or 2" fiberglass wrap with a sealed vapor barrier. A leaky vapor barrier results in duct sweating, causing wet insulation does not insulated.

Heat transfer through poorly insulated systems can result in over 50% loss in operating capacity. Sweating ducts also results in rusting that leads to premature duct failure. Carefully follow the industry practices to insure a well designed duct system.

Air supply diffusers must be selected and located carefully. They must be sized and positioned to deliver treated air along the perimeter of the space. If they are too small for their intended air flow, they can be noisy. If they are not located properly, they can cause drafts in the rooms. Return air grilles must be properly sized to carry air back to the blower. If they are too small they also cause noise. The installers should balance the air distribution system to ensure proper air flow to all rooms in the home. This ensures a comfortable living space.

6. INSTALLATION INSTRUCTIONS

! WARNING

These instructions are intended as an aid to qualified, service and installation personnel for proper installation adjustment and operation of this unit. Read these instructions thoroughly before attempting installation or service this equipment. **Failure to follow these instructions may result in improper installation, service or maintenance and could possibly result in fire, electrical shock, property damage, personal injury or death.**

This product is designed and manufactured to permit installation in accordance with National Codes. **It is the installer's responsibility to install the product in accordance with National Codes and/or prevailing local codes and regulations.** The manufacturer assumes no responsibility for equipment installed in violation of any codes or regulations.

The United States Environmental Protection Agency (EPA) has issued various regulations regarding the introduction and disposal of refrigerants from this unit. Failure to follow these regulations may harm the environment and can lead to the imposition of substantial fines. Because these regulations are subject to revision any repair on this unit should be done by a certified technician.

The manufacturer's warranty does not cover any damage failure caused by the air conditioning system. **You should be aware that the use of unauthorized components, accessories or devices may adversely affect the operation of the air conditioner and may also endanger life and property.** The manufacturer disclaims any responsibility for loss or injury due to the use of such unauthorized components, accessories or devices. **Attach the service panel to the outdoor unit after to prevent.** If the service panel is not attached securely, it could result in a fire or an electric shock due to dust, water, etc.

INDOOR COIL MAINTENANCE

Inspect the indoor coil at least once a year for cleanliness and clean as necessary.

1. The coil can be cleaned when dry. If it is coated with lint or dirt, blow compressed air or nitrogen (NEVER USE REFRIGERANT) through the supply air side of the coil fins. Place a sheet of metal or cardboard under the return air side of the coil to catch any debris before it gets into the air handler.
2. If the coil is coated with oil or grease, clean with a mild detergent and water solution. Rinse thoroughly with clear water. Be careful not to get water into the air handler.
3. After cleaning the coil, inspect the drain pan and condensate line. Remove any debris from the pan and flush with clear water.
4. High pressure water can be used to clear any clog in the condensate line.

WARNING: DO NOT USE CAUSTIC HOUSEHOLD DRAIN CLEANERS IN THE CONDENSATE PAN OR NEAR THE INDOOR COIL. THESE DRAIN CLEANERS CAN QUICKLY DAMAGE THE INDOOR COIL.

UNIT DIMENSIONS

a. For HB2400VD1M20 air handler

PHYSICAL DIMENSIONS

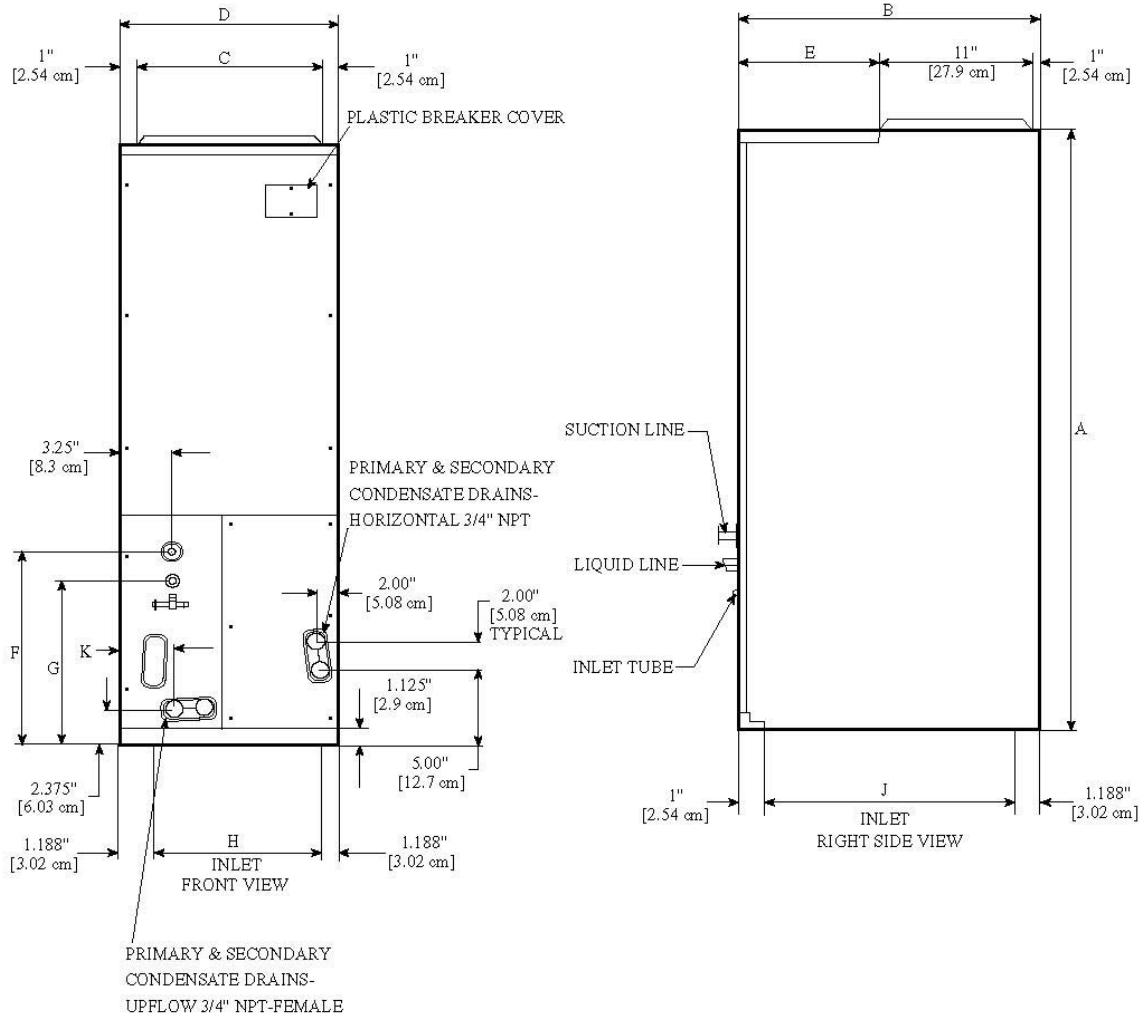

A	B	C	D	E	F	G	H	J	K
46.75	22	17.5	19.5	10	14.5	11.937	17.125	19.812	3.375
[118.7cm]	[55.9cm]	[44.5cm]	[50.0cm]	[25.4cm]	[36.8cm]	[30.3cm]	[43.5cm]	[50.3cm]	[8.57cm]

b. For HB3600VD1M22 air handler

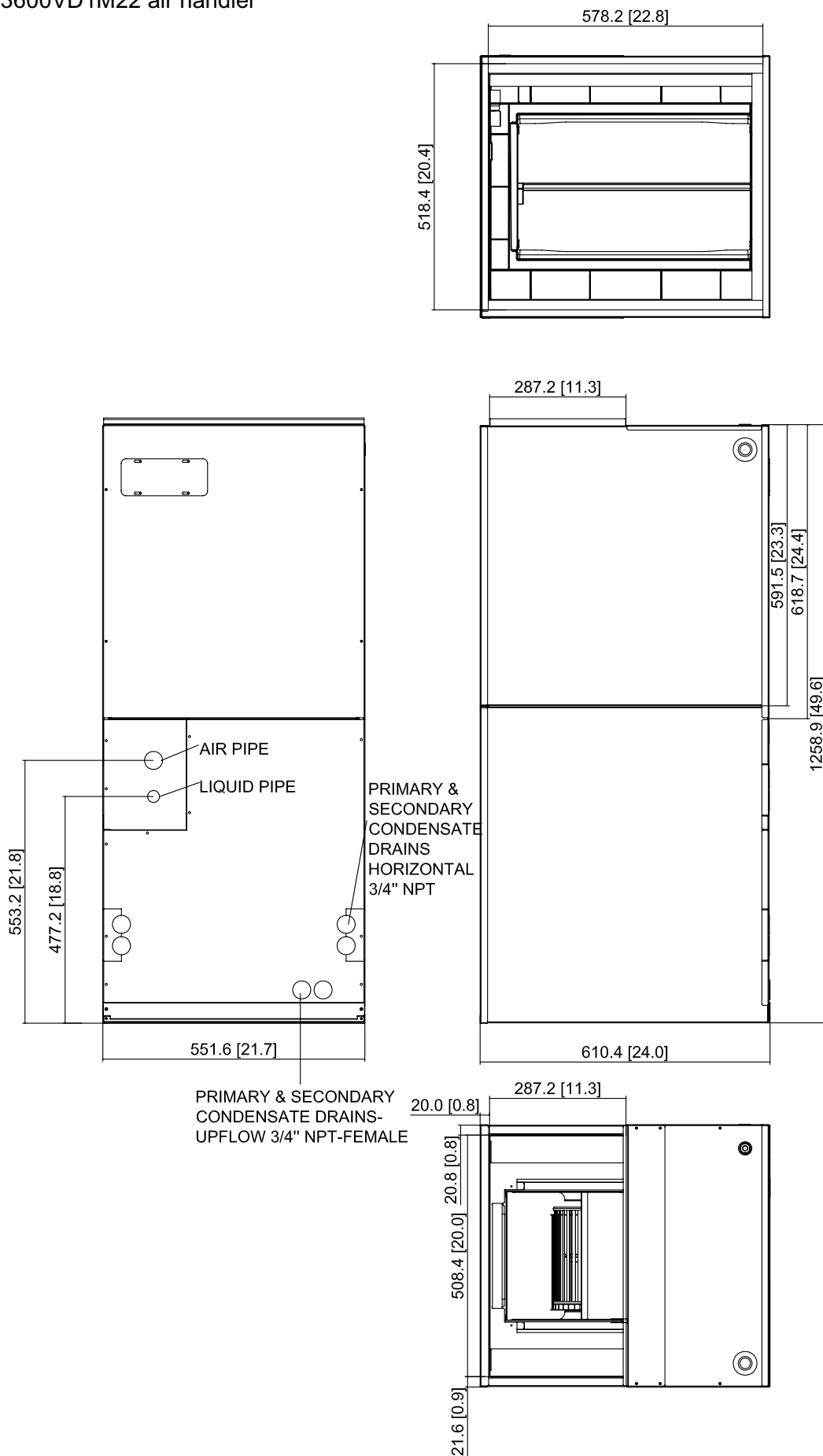

c. For HB48/6000VD1M22 air handler

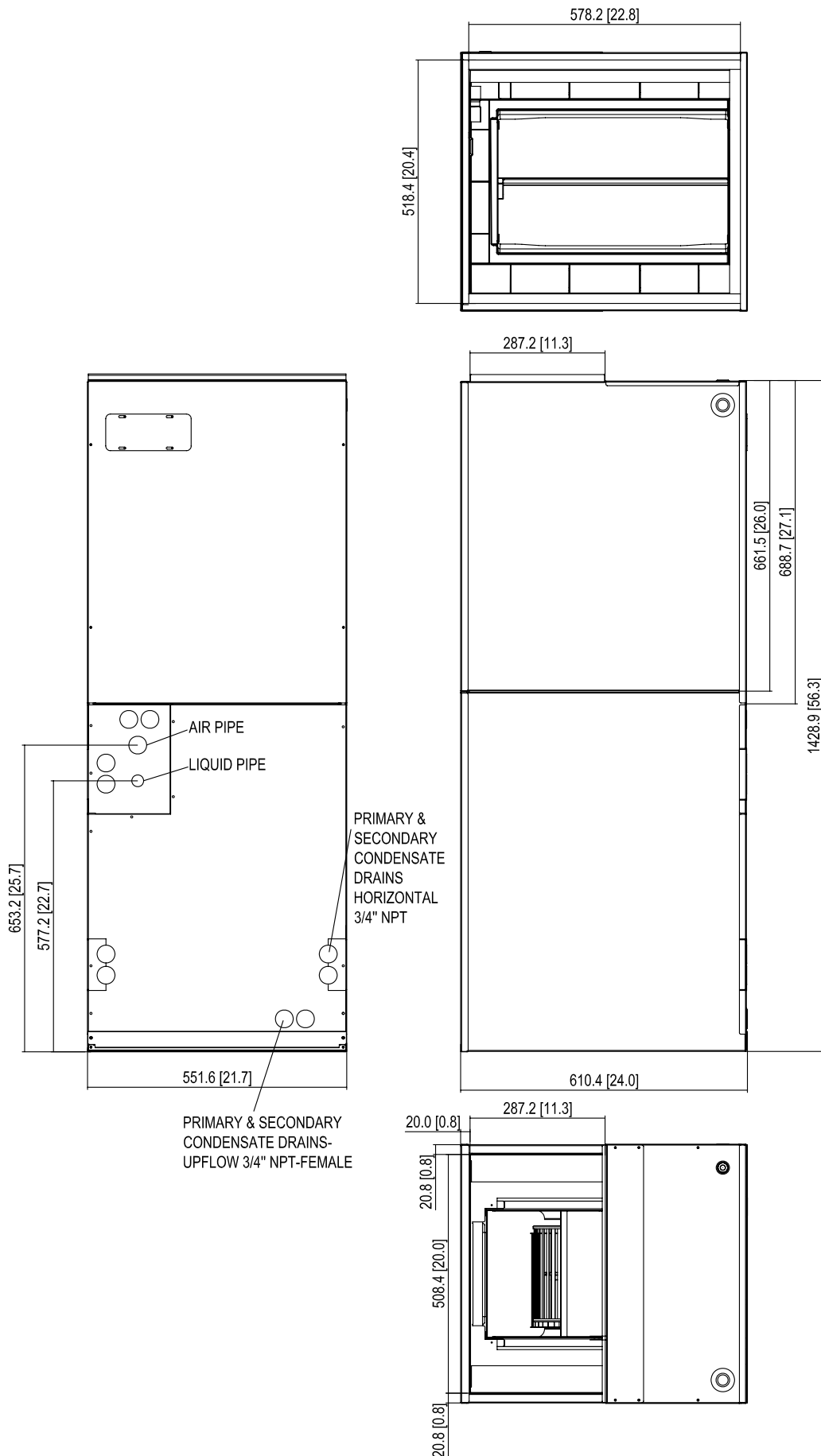

Before installing the air handler insure that it is properly sized and that adequate power is available.

This air handler can be installed in the vertical or right horizontal position without modification. The horizontal left and downflow positions require product modification.

This product is designed for zero inch (0") clearance; however, adequate access for service, maintenance or replacement must be considered beffor installation. This unit can be installed on a service stand or return air properly as necessary.

In an attic installation, a secondary drain pan must be provided by the installer and placed under the entire unit with a separate drain line properly sloped and terminated in an area visible to the owner. This secondary drain pan is required in the event that there is a leak or main drain blockage. Closed cell insulation should be applied to the drain lines in unconditioned spaces where sweating may occur.

Install air handlers in garages, warehouses or other areas where they may be subjected to mechanical damage must be suitably guarded against such damage by installing behind protective barriers, being elevated or located out of the normal path of vehicles. When installed on a base, the base must also be protected by similar means.

Heating and cooling equipment located in garages, which may generate, spark or flame capable of igniting flammable vapors, must be installed with the ignition source at least 18" above the floor level.

When more than one air handler is installed in a building, permanently identify the unit as to the area or space serviced by that air handler.

AIRFLOW ORIENTATION

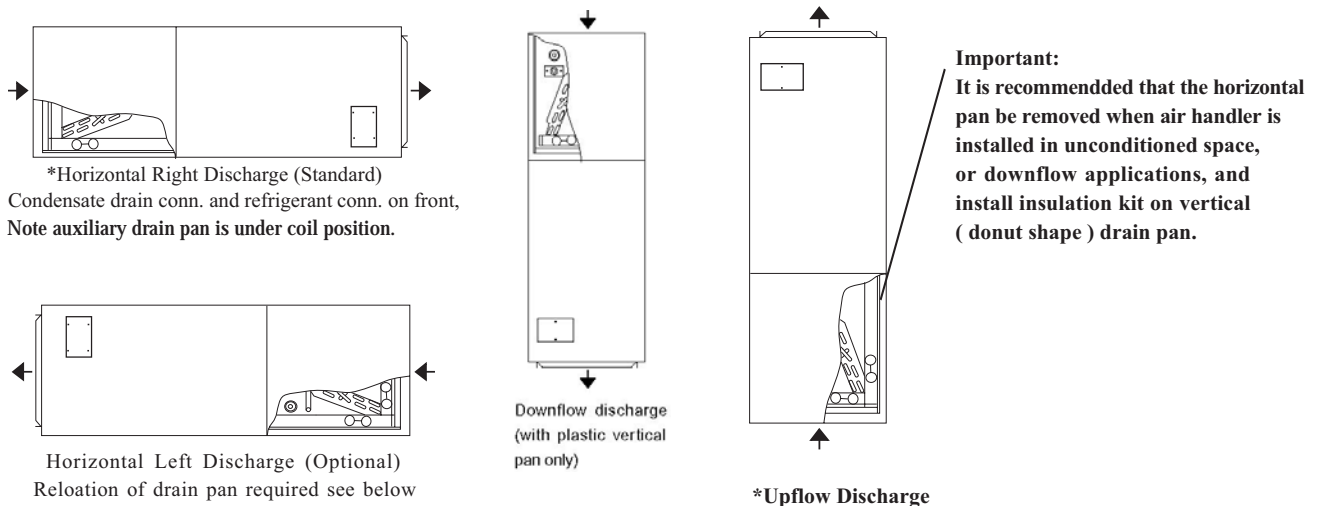

Fig.6-4

TABLE 8-4 Airflow for 13SEER air handlers

Static pressure CFM MODEL	Indoor fan speed	0.1	0.15	0.20	0.25	0.30	0.35	0.40	0.50
		HB2400VD1M20	L	630	614	599	585	571	556
	H	900	877	856	835	816	795	766	737
HB3600VD1M22	L	---	1125	1093	1062	1033	1006	976	946
	H	---	1240	1208	1177	1148	1121	1091	1061
HB4800VD1M22	L	---	1480	1442	1404	1366	1328	1290	1252
	H	---	---	1650	1605	1560	1515	1470	1425
HB6000VD1M22	H	---	---	1800	1745	1690	1635	1580	1525
HB6000VD1M22-E	H	---	---	1850	1795	1740	1685	1630	1575

HORIZONTAL LEFT-HAND INSTALLATION

Instructions: Follow steps below carefully to modify air handler for left hand.

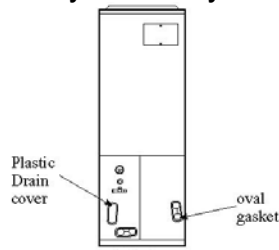

Fig.6-5

- 1) With Air handler in the vertical position, remove all three access panels.
- 2) Remove J-shape metal bracket holding coil pan in place. Slide out the "A" coil pan assembly from the air handler cavity with horizontal drain pan on the right side. Remove oval gasket from horizontal pan drain and also remove the plastic drain cover from the lower left access panel. Fig. 6-5
- 3) Relocate horizontal pan on the left-hand side of the "A" coil assembly.
- 4) Knockouts are located within the drain assemblies. Carefully remove only the correct knockouts using a hammer and screw driver for each application, making sure the primary and secondary drains are open and clear of burrs and debris. Remove secondary drain knockout only if this drain is required by local codes and practices.

WARNING: If incorrect knockouts are removed, water damage could occur.

- 5) Reinstall the "A" coil pan assembly in the Air handler with the horizontal drain pan on the left-hand side.

Note: Push the assembly completely to the rear of the cavity and assure it slips into channel bracket at the rear of the cavity. Local codes and practices.

- 6) Replace the J-shape metal bracket or brackets on the vertical drain pan and place the plastic oval gasket on horizontal drain pan. Reinstall access panels and flowrator making sure not to over torque screws. Snap in the drain cover on the right lower service panel.
- 7) The Air handler can now be placed in its left horizontal position as shown in Fig.6-6. The Air handler must be leveled and then pitched 1/4" toward drain side. **Important:** Drain pan must be tested for proper drainage by pouring water into the pan. Traps must be installed on both the primary drain and the secondary drain if used.

- 8) In all cooling applications, a secondary drain pan must be provided by the installer and placed under the entire unit with a separate drain line properly sloped and terminated as required by local codes.
- 9) Before setting up flowrator assembly for field brazing see page 12 or read the **Warning label** on the lower access panel.
- 10) Incorrect installation or improper practices could affect the product warranty.

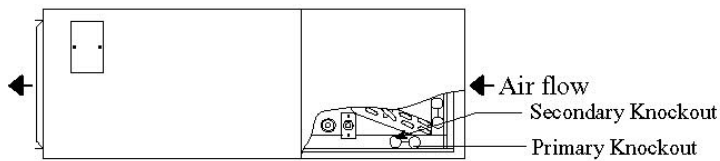

Fig. 6 -6

Note: the *M22 units can be installed as upflow discharge.

DOWNFLOW INSTRUCTIONS

Important: Read instructions below carefully

1. Before putting the Air Handler in the downflow position, remove the three access panels and remove the metal coil retaining bracket and filter close off. Then remove the horizontal and vertical drain pans. The horizontal pan is not required for downflow application.
2. After removing the coil, turn the Air Handler to the downflow position and relocate the (8) brackets which include (1) tie bracket (1) rear channel brackets, (2) zee coil supports, (2) stiffener brackets, and (2) 3"2 flat insulation retaining brackets. In effect, brackets, coil and 2 lower access panels will be assembled 180 degrees from their former position and shifted down with return in up position as shown in fig.1 and fig. 2.
3. Assemble drain pan insulation kit to the bottom of the drain pan to prevent drain pan from sweating during operation.
4. Place 3" flat insulation retainer on the bottom of each coil slab against the aluminum fins as shown in Fig.3. This will reduce the potential for water blow-off into the air stream.
5. Slide the coil assembly into Air Handler and reattach the metal coil retainer bracket to tie bracket. See Fig.2. Then reattach the upper access panel followed by the two lower access panels to match the tubing and drains.
6. A 4" to 3" removable panel is recommended at the point where the duct meets with the return part of the Air Handler unit to allow easier removal of coils that are too tall.
7. The "HB" coils are shipped with a check flowrator for use with either cooling or heat pump outdoor section which is accessible from the outside of the unit.

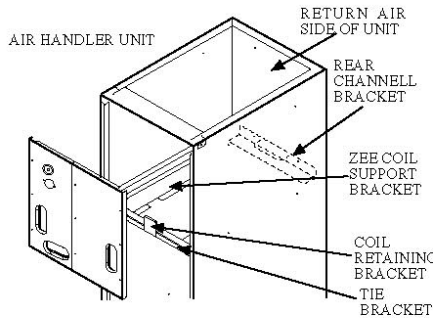

NOTE: THE FILTER PROVISION IS NOT APPLICABLE IN THIS DOWNFLOW APPLICATION

Fig.1

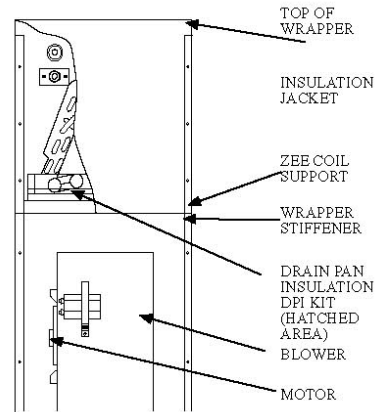

Fig.2

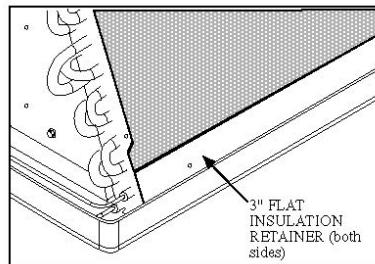

Fig. 3

Fig. 6-7

WARNING: The "A" coil contains 150 p.s.i.g. of air pressure

REFRIGERANT TUBING

Refrigerant tubing should be installed so that it is properly supported, sized and sloped. The vapor and liquid lines must be supported or routed to avoid strain or vibration. To avoid damage that can be caused by condensation, insulate the suction tube with a closed cell insulation with the seams sealed. The insulation should terminate at the tubing entrance to the air handler. Do not reduce the recommended tubing size.

CONDENSATE REMOVAL

THIS AIR HANDLER EMPLOYS A DRAW-THROUGH COIL, THEREFORE A LIQUID SEAL TRAP MUST BE INSTALLED IN THE DRAIN LINE(S) TO ALLOW FOR OR PROPER CONDENSATE REMOVAL.

The condensate trap must be a "P" trap as shown bellow.

The total workable height of this trap, in inches, must exceed the total negative pressure, in inches of water, as measured in the return duct.

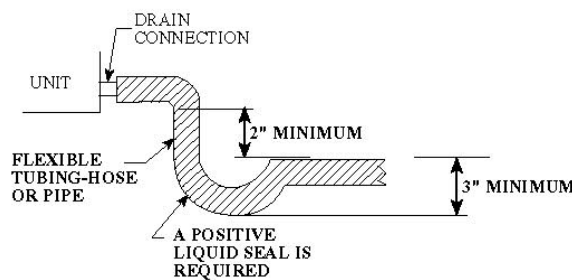

Fig.6-8

The condensate drain line must be at least 3/4 NPT, for each unit. Use caution when tightening the adapter at the drain pan connection, to prevent damage to the plastic drain pan. A joint compound should be used to prevent leakage and act as a lubricant.

When copper tubing is used for the condensate line, adequate caution must be taken to prevent damage to the plastic drain pan during the soldering process. All condensate drain lines and drain traps should be adequately insulated.

The unit and the auxiliary drain pan must be adequately elevated to insure proper drainage.

Use of a condensate removal pump may be necessary. This condensate pump should have provisions for shutting off the control voltage should a blockage in the drain line or condensate pump failure occur. A trap must be installed between the unit and the condensate pump.

Important: The evaporator coil may have residual oils that could dissolve Styrofoam and certain types of plastics. Therefore a removal pump or float switch must not contain any of these materials.

ELECTRICAL CONNECTIONS

The required electrical power supply information is located on and rating plate on the exterior of the unit. Wiring selection must be in accordance with local codes, or in absence of local code, the National Electrical Code. A disconnect means should be installed within sight of the unit, as required by code. Copper wire is recommended for all electrical connections.

When an optional heat kit is installed refer to the electrical requirements in that kit.

The wiring diagram included in the heat kit must be placed over the wiring diagram on the air handler. All pertinent information, such as the rating plate, included in the optional heat kit must be applied to the Air Handler as indicated.

The use of copper connections are recommended for all modification or field supplied accessories inside the air handler electrical section inside the control box.

Model(indoor units)	Min. ampacity 208/230V	Max.Overcurrent(A) 208/230V	Fan motor capacitor(UF)	Blower motor FLA	Blower motor HP
HB2400VD1M20	1.1	15/15	8	0.9	1/8
HB3600VD1M22	2.5	15/15	8	2.0	1/3
HB4800VD1M22	3.3	15/15	8	2.6	1/2
HB6000VD1M22	4.4	15/15	12	3.5	3/4
HB6000VD1M22-E	5.0	15/15	/	4.0	3/4

Table 6-1 Electrical parameter

A MEANS OF STRAIN RELIEF TO PROTECT THE ENTRY BLOCK WIRE CONNECTION.
 When an optional electric heat kit is installed refer to the electrical requirements for that kit. The ampacity and over-current protection shown above is only for "HB" air handlers installed without a heat kit.

Electric control function for air handlers



Port definition:

C1, C2: power input port, 24VAC;

C3: control signal input port, 24V;

P1, P2, P3: fan motor control port --- P1 is COM port, P3 is normal OFF, P2 is normal OPEN;

K1: fan motor relay

Function description

1. K1 will open 15 seconds later after there is 24V signal from C3;
2. K1 will open 30 seconds later after there is no signal from C3;
3. AC contactor control the electric heater solely.

Connecte P1 with netural wire of fan motor, connect normal OPEN port P2 with power input port of AC contactor, supply P1 the power of fan motor when there is signal from C3. connect normal OFF port P3 with power output port of AC contactor, to ensure the fan motor work whenever there is or is not control signal during heater woring.

7. WIRING DIAGRAM

